

OWNER'S MANUAL: Hinged Swing-Out Network Cabinets

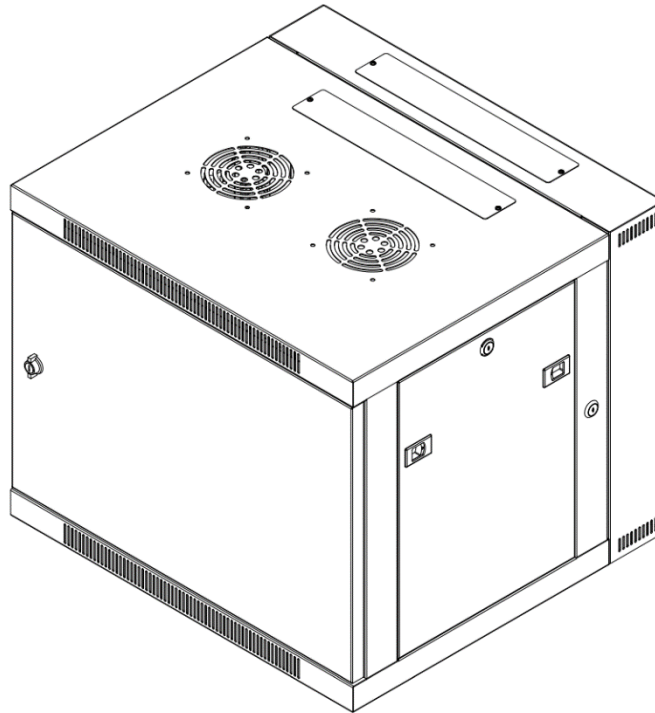

THIS MANUAL APPLIES TO THE FOLLOWING SKUs: SMC-SMT6406D-D, SMC-SMT6506D-D, SMC-SMT6606D-D, SMC-SMT6409D-D, SMC-SMT6509D-D, SMC-SMT6609D-D, SMC-SMT6412D-D, SMC-SMT6512D-D, SMC-SMT6612D-D, SMC-SMT6506D, SMC-SMT6509D

Keep this information for further reference.

Thank you for purchasing a SMC product.

Please examine the product for any damaged parts. If any part is damaged or missing, contact SMC for assistance. Do not attempt to install or use product if it has been damaged.

During installation, lay product contents on cardboard or other protective surface to avoid any damage. Improper installation or use of this product could result in damage to the product, other equipment, or personal injury. It is recommended that installation be performed by a qualified installer. SMC cannot be held responsible for damage to equipment or personal injury resulting from improper use or installation of product. If product is intended to store/mount equipment, please ensure the equipment stored/mounted does not exceed the specified weight capacity.

Limitations of Liability: In no event will Infinite Electronics International, Inc. be liable for any damages, whether direct or indirect, special, punitive, incidental or consequential damages (including, but not limited to, lost profits or revenue, loss of use, lost business opportunities or loss of goodwill) or for the costs of procuring substitute products, arising out of or in connection with the use of the product, whether such liability arises from any claim based upon contract, warranty, tort (including negligence), product liability or otherwise, whether or not seller has been advised of the possibility of such loss or damage. In no event will seller's total cumulative liability, from all causes of action and all theories of liability, exceed the total amounts actually paid to seller by customer under the order that gives rise to any liability hereunder.

1. Parts Identification

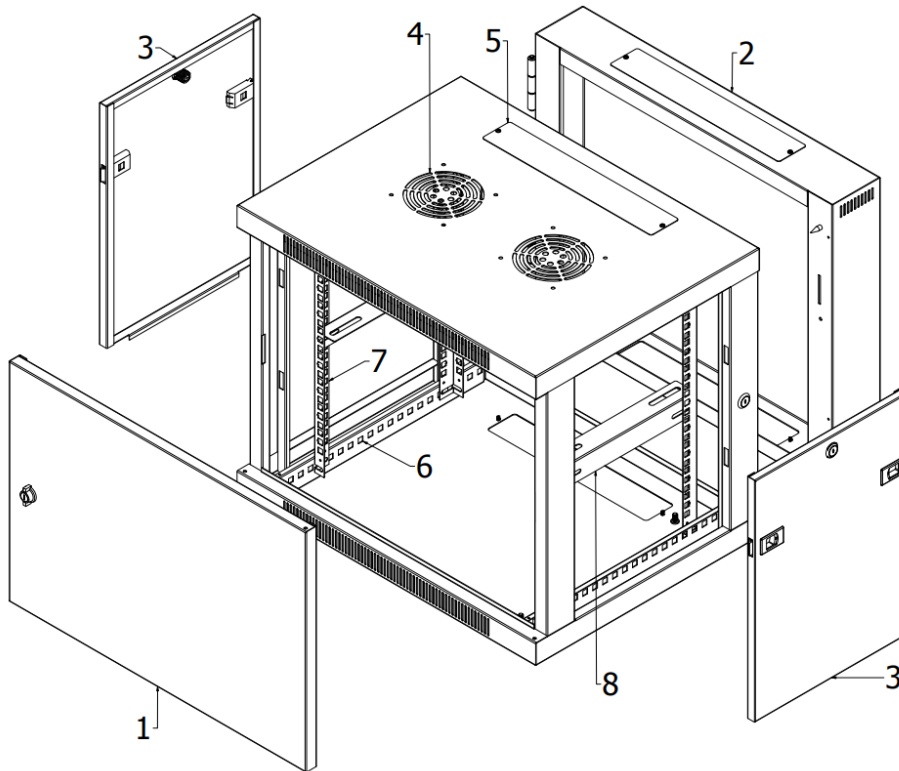

1. Front Door
2. Hinged Back Door
3. Removable Side Panel (x2)
4. Fan Vents
5. Removable Cable Access Panels (x4)
6. Horizontal Rails (x4)
7. Vertical Mounting Rails (x4)
8. "L" Brackets (x2)

Hardware Included

- M6 Mounting Screws x12
- M6 Plastic Washers x12
- M6 Cage Nuts x12
- Anchors x4

2. Enclosure Configuration

-Door Locks

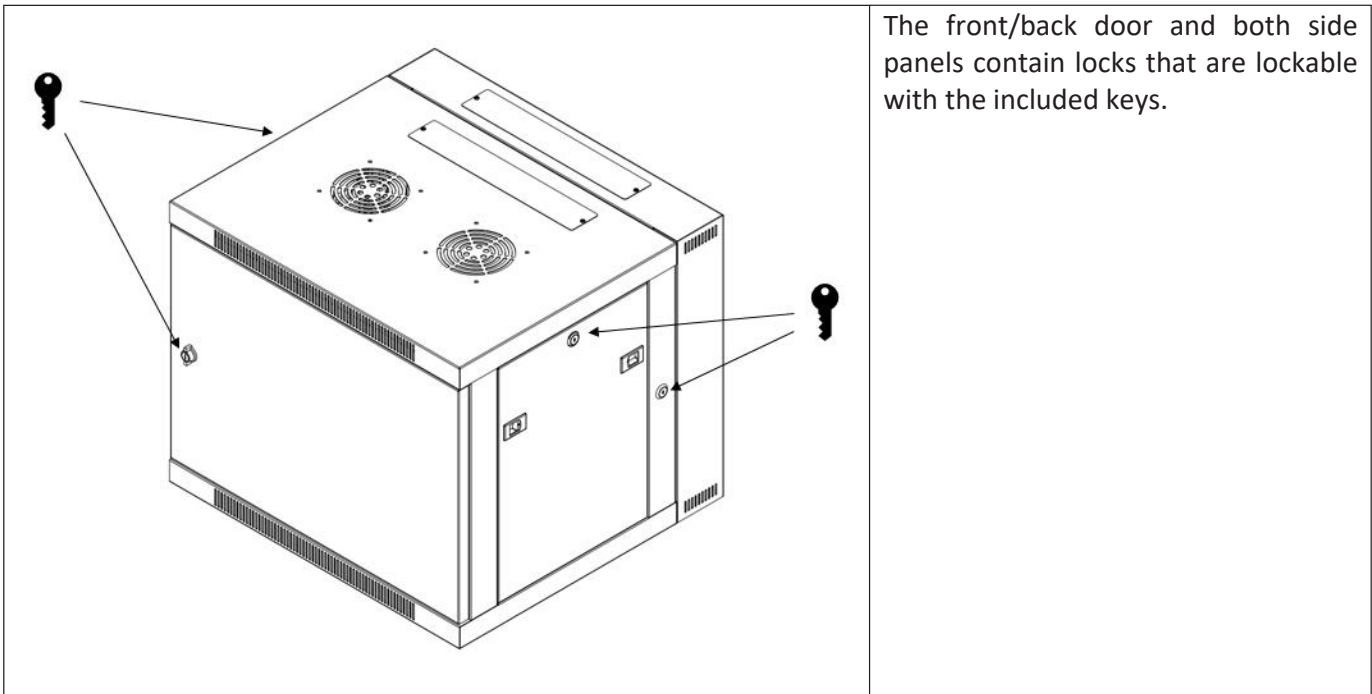

The front/back door and both side panels contain locks that are lockable with the included keys.

-Cable Access and Management

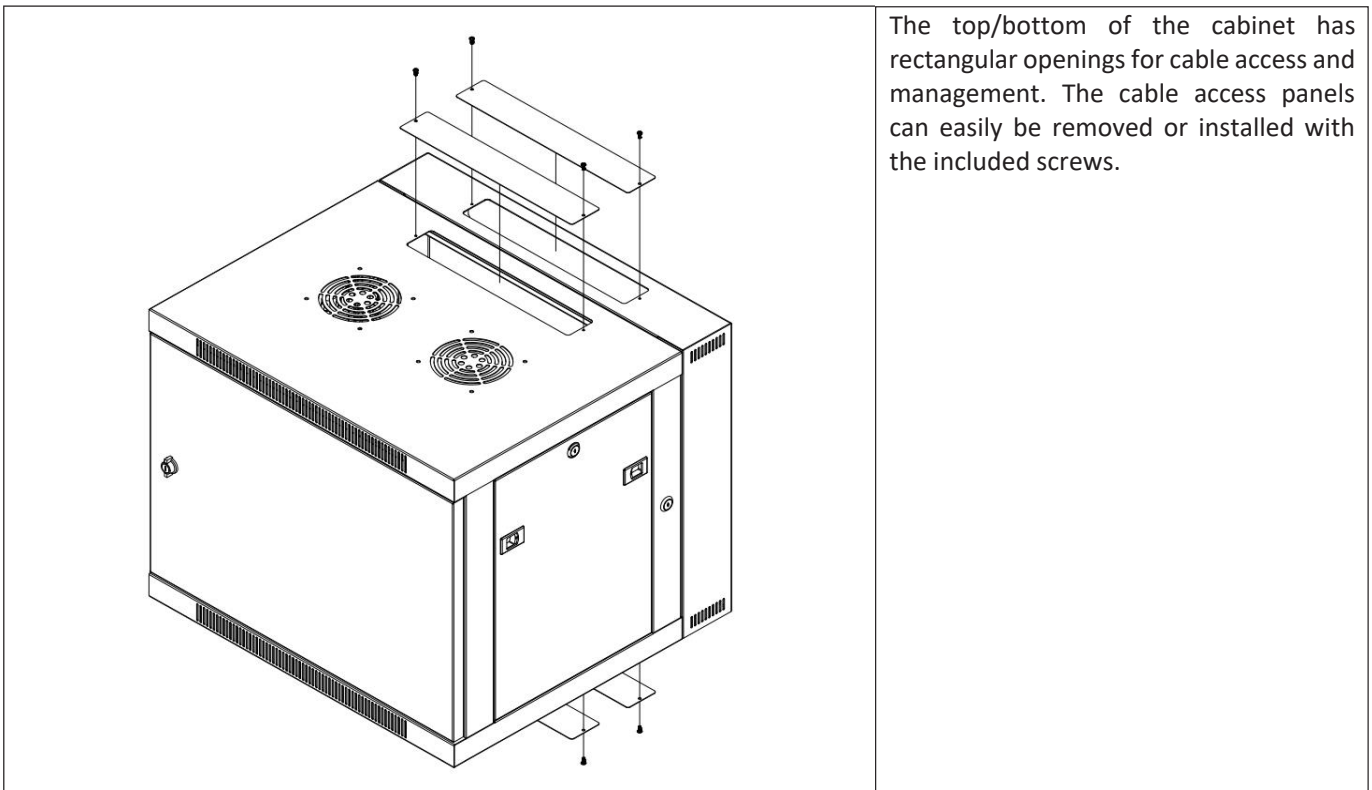

The top/bottom of the cabinet has rectangular openings for cable access and management. The cable access panels can easily be removed or installed with the included screws.

-Adjusting Mounting Rail Depth

1. Each vertical Mounting Rail is connected to the enclosure with 2 screws and 2 cage nuts: 1 set in the upper corner and another in the lower corner. Using a Phillips-head screwdriver, remove the screws that fasten the rails to the enclosure.
2. Move the cage nuts to the desired depth and reinstall.
3. Slide the mounting rails to the desired depth and reattach them.

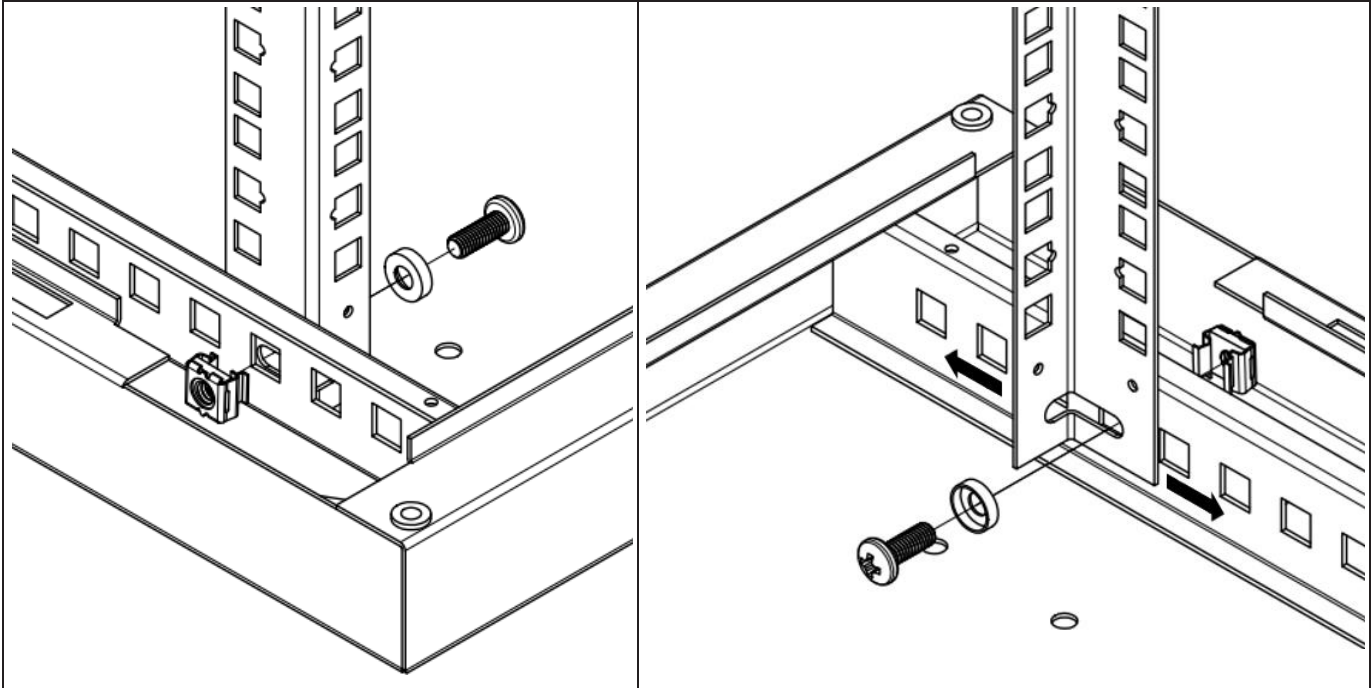

3. Mounting the Enclosure to the Wall

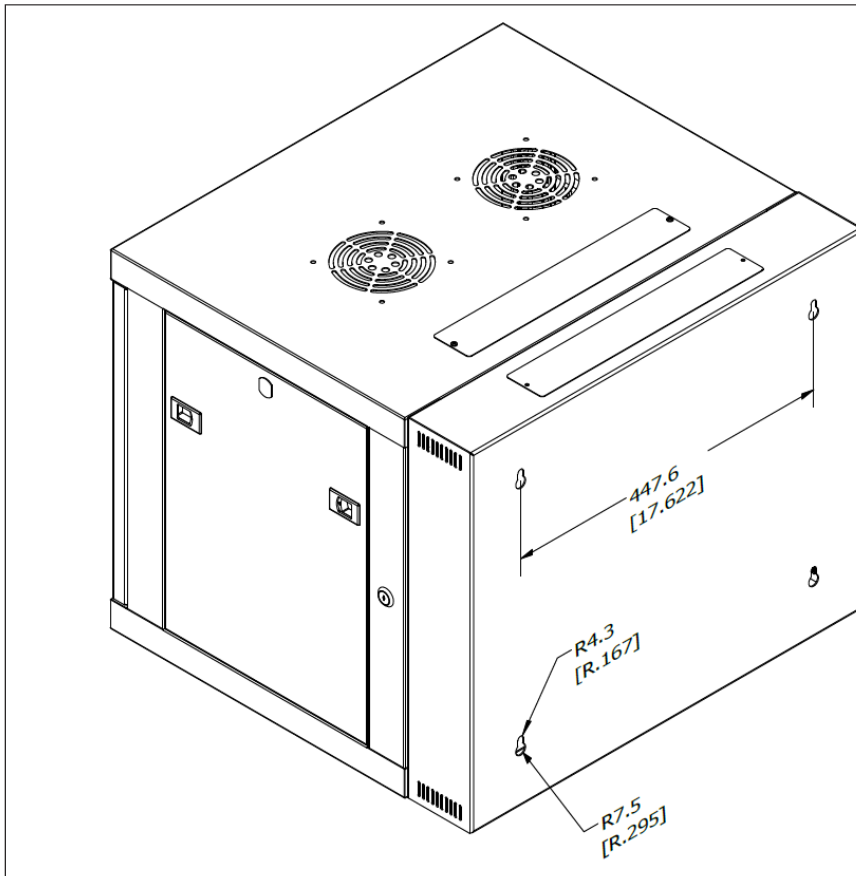

Attach the rack to a wall or other suitable mounting surface using appropriate anchors. The included anchors are intended for use on a concrete wall.

The mounting holes are spaced 17.62" (447.6mm) and as reflected in the diagram.

Warning: Do not attempt to mount to wall when equipment is already mounted inside the rack. The rack can hold up to 130 pounds evenly distributed. Make sure the wall surface can hold both the weight of the cabinet and the rack-mounted equipment.

4. Equipment Installation

1 Rack Unit	
<p>1.750" (44.45mm)</p>	<p>0.625" (15.90mm)</p> <p>0.625" (15.90mm)</p>
<p>Note: The unit comes with two different kinds of screws for equipment installation, black and silver. Use the black mounting screws if you are securing your equipment to the square hole side of the mounting rail. Use the silver screws if you are securing your equipment to the tapped hole side of the mounting rail.</p>	

-Installing Cage Nuts

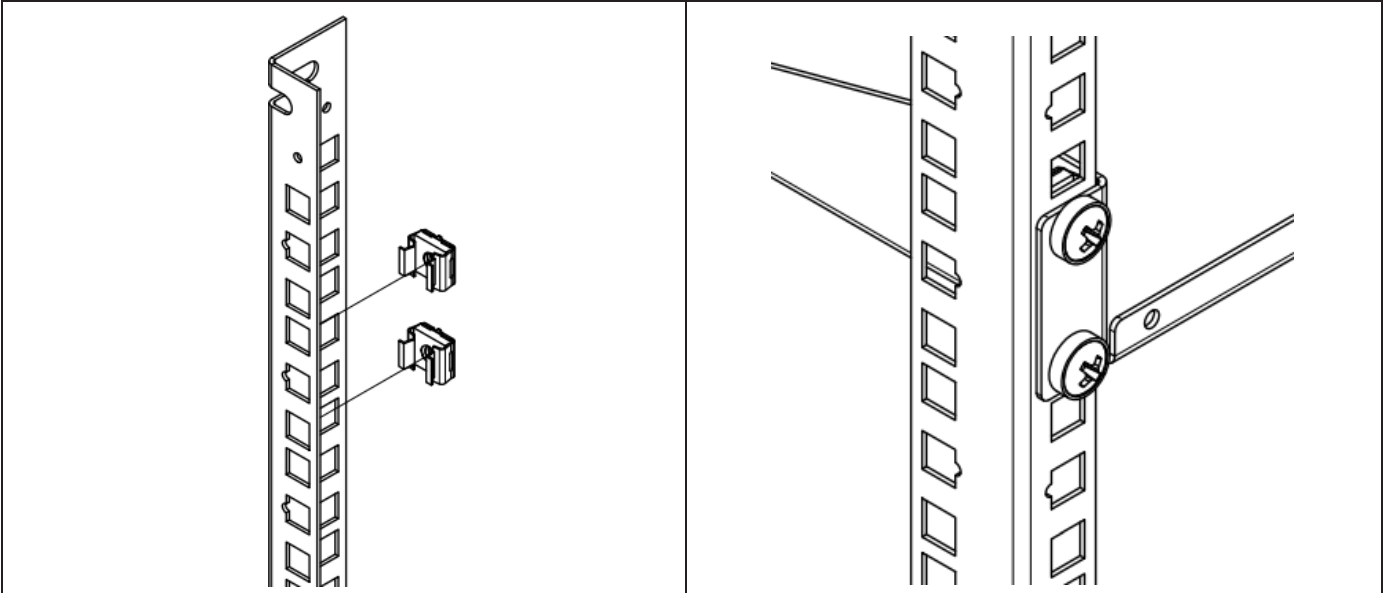

1 Locate the numbered square openings in the mounting rails where you plan to install your equipment. You will install cage nuts (included) into the square openings to provide an attachment point for the mounting screws (included). Note: Consult your equipment documentation to determine how many cage nuts will be required and where they will need to be installed.

a- From the inside of the mounting rail, insert one of the flanges of the cage nut through the square opening. Press it against the side of the square opening. Each flange should engage one side of the square opening, not the top or bottom.

b- Compress the cage nut at the sides slightly to allow the remaining flange to fit through the square opening. When the cage nut is properly installed, both flanges will protrude through the square opening and will be visible on the outer surface of the mounting rail. Repeat steps 1a and 1b until all required cage nuts are installed.

2 After installing the required cage nuts, use the included black mounting screws and cup washers to secure your equipment to the rack rail. Place the cup washers between the screws and the equipment mounting brackets.