

Show Me CABLES

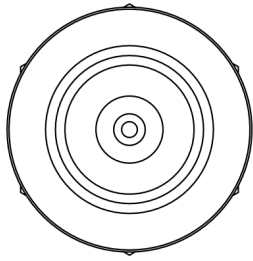

2X TNC JACK

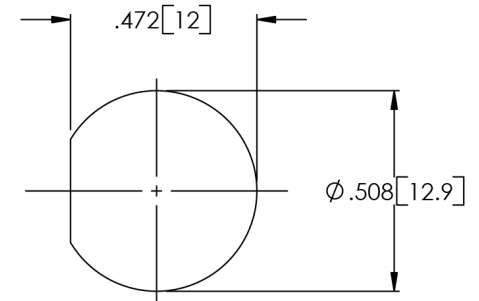
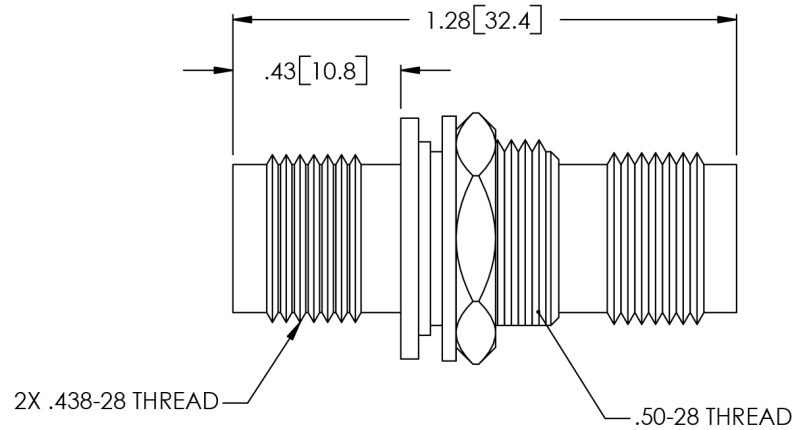

RECOMMENDED PANEL
OPENING

NOTES:

MATERIAL:

BODY: BRASS
CONTACT PIN: PHOSORUS BRONZE
INSULATOR: DELRIN
WASHER: STEEL
NUT: BRASS

FINISH:

BODY: NICKEL
CONTACT PIN: GOLD
WASHER: NICKEL
NUT: NICKEL

MISCELLANEOUS:

ADAPTERS SHALL BE INDIVIDUALLY PACKAGED IN POLY BAG

REVISIONS			
REV	DESCRIPTION	DATE	APPROVED
A	RELEASED FOR PRODUCTION		
B	ECN# 1204; PRODUCT VALIDATION		
C	ECN# 2688; INSULATOR MATERIAL WAS TEFLON		
D	ECN 3119; UPDATE DWG FORMAT		

RoHS Compliant ✓

DIMENSIONS ARE IN INCHES [mm] UNLESS OTHERWISE SPECIFIED, TOLERANCES TO BE: .X ±.1 [2.5] ANGLES ±2° .XX ±.01 [.25] .XXX ±.005 [.13] OVERALL CABLE LENGTH TOL: ≤ 60 [1524] +3 [76.2] / -0 > 60 [1524] +5% / -0%	APPROVALS	DATE
	DRAWN BY C.MCCORMICK	09/28/2001
	CHECKED BY ENG	09/28/2001
	APPROVED BY R.CARRICK	09/28/2001
PROJ	CONFIGURATION DETAILS OF UNDIMENSIONED FEATURES MAY VARY	

CATEGORY	COAXIAL		
PRODUCT DESCRIPTION	TNC DUAL FEMALE BULKHEAD F TYPE		
SIZE	FSCM NO. A 43321	DWG. NO.	REV. D
SCALE: NONE		CAD FILE: BA1090.SLDRW	SHEET 1 OF 1