

6

5

4

3

2

1

## REVISION

ZONE	REV	DESCRIPTION	DATE	CHANGED BY	APPROVED
	A	INITIAL RELEASE	02/08/2024	KGLEBOVA	GUTTADAURO

F

F

E

E

D

D

C

C

B

B

A

A

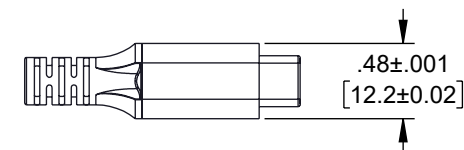
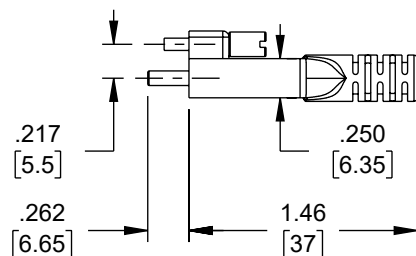
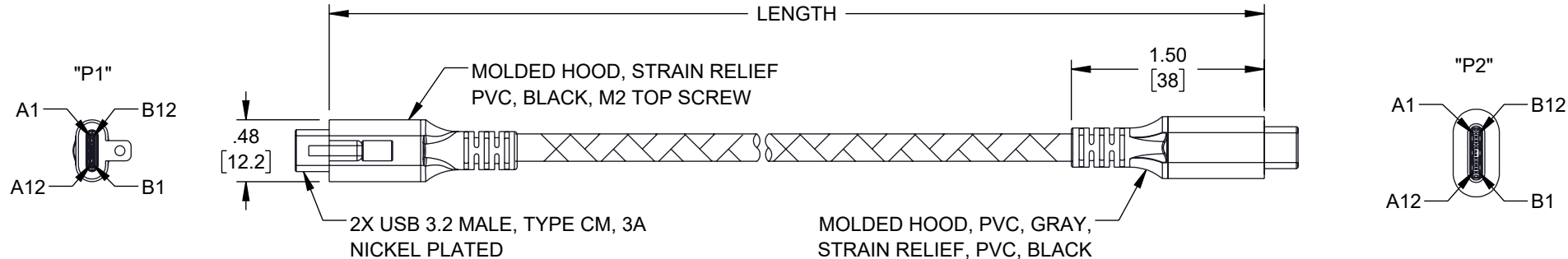

## WIRING DIAGRAM

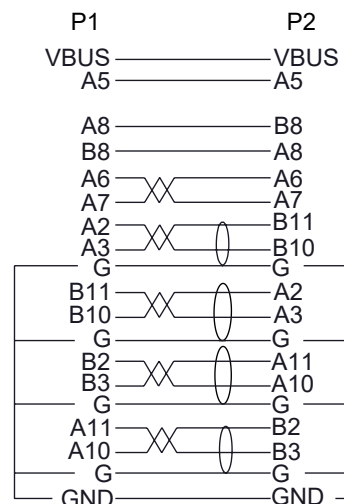

## NOTES:

- CABLE: (32AWG\*1P+D+AL+HM)\*4C+32AWG\*1P+32AWG\*4C+  
+24AWG\*2C+F+D(24AWG), OD: 5.2mm ± 0.2 mm  
JACKET: PVC, BLACK, NYLON BRAID, BLACK.

## ELECTRICAL TEST:

- 100% OPEN SHORT MISS WIRE TEST
- CONTACT RESISTANCE: 5 OHM MAX.
- INSULATION RESISTANCE: 10M OHM MIN.
- HI-POT TEST: DC 300V/10 ms
- PASS 5Gbps/5V3A TEST

## MISCELLANEOUS:

- CABLE ASSEMBLY TO BE TESTED FOR CONTINUITY.
- CABLE ASSEMBLY SHALL BE INDIVIDUALLY PACKAGED.

THE INFORMATION CONTAINED IN THIS DRAWING IS THE SOLE PROPERTY OF INFINITE ELECTRONICS, INC. ANY REPRODUCTION IN PART OR WHOLE WITHOUT THE WRITTEN PERMISSION OF INFINITE ELECTRONICS, INC. IS PROHIBITED. THESE COMMODITIES, TECHNOLOGY OR SOFTWARE WERE EXPORTED FROM THE UNITED STATES IN ACCORDANCE WITH THE EXPORT ADMINISTRATION REGULATIONS. DIVERSION CONTRARY TO U.S. LAW PROHIBITED.

UNLESS OTHERWISE SPECIFIED  
LEADING DIMENSIONS ARE INCHES  
DIMENSIONS IN [ ] ARE MILLIMETERS

TOLERANCES:  
X = ±.2 [5] | FRACTIONS  
XX = ±.02 [0.5] | ± 1/32  
XXX = ±.005 [0.13] | ANGLES ± 1°

CABLE LENGTH TOLERANCES:  
≤12 [305] = +1 [25] / -0  
>12 [305] ≤ 60 [1524] = +2 [51] / -0  
>60 [1524] ≤ 120 [3048] = +4 [102] / -0  
>120 [3048] ≤ 300 [7620] = +6 [152] / -0  
>300 [7620] = +5% / -0

ALL DIMENSIONS ARE FOR REFERENCE ONLY  
AND SUBJECT TO CHANGE WITHOUT NOTICE.  
UN-DIMENSIONED NON-CRITICAL FEATURES  
MAY VARY IN SIZE AND LOCATION  
COLORS MAY VARY

**Show Me**  
CABLES

an INFINIT® brand

Website: [www.ShowMeCables.com](http://www.ShowMeCables.com)  
Phone: 1.888.519.9505

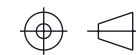

INTERPRET ALL DIMENSIONS AND  
TOLERANCES PER ASME Y14.5

SCALE SHEET

NONE 1 OF 1

DESCRIPTION  
USB 3.2 USB C MALE TOP SCREW ONE SIDE, 5V, 3A, 5Gbps

SIZE	CAGE CODE	DRAWN BY	ITEM NO.	REV
A	3SVT8	KGLEBOVA	SU32CC-MLMS	A

6

5

4

3

2

1