

6

5

4

3

2

1

REVISION					
ZONE	REV	DESCRIPTION	DATE	CHANGED BY	APPROVED
	A	INITIAL RELEASE	01/29/2024	AKRESOWSKI	GUTTADAURO

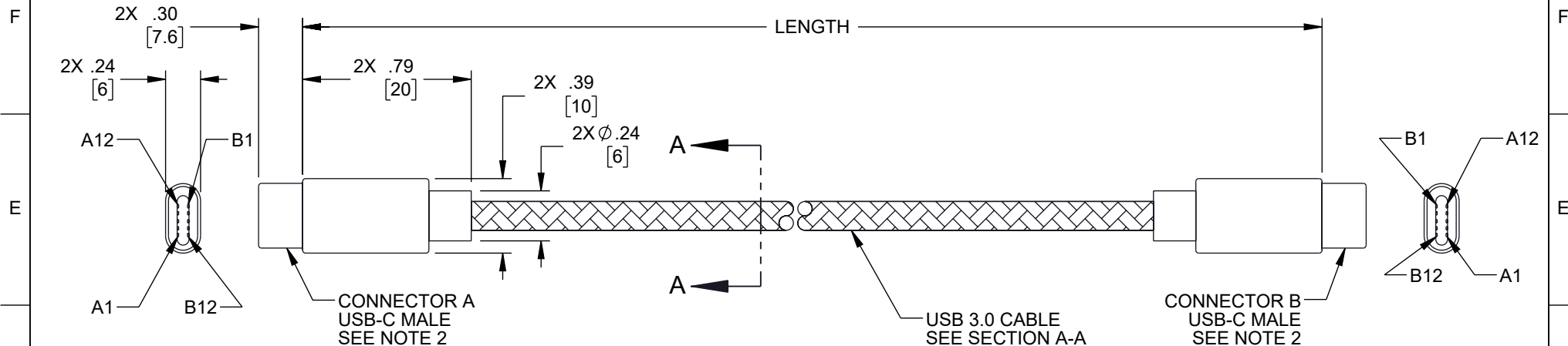

WIRING MAP		
CONNECTOR A		CONNECTOR B
V	-----	V
A7	-----	A7
A6	-----	A6
A5	-----	A5
A3	-----	A3
A2	-----	A2
GND	-----	GND
B10	-----	B10
B11	-----	B11

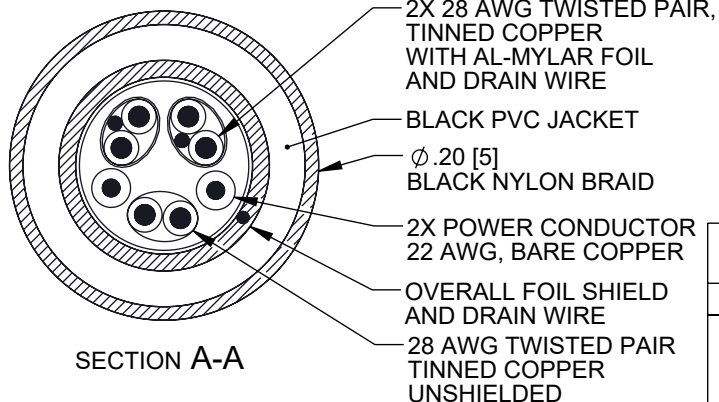

TABULATION BLOCK SEE NOTE 3		
ITEM NO.	LENGTH ± 1.2 [30]	QTY PER KIT
SU3-CC-3PK	3 FT	1
	6 FT	1
	10 FT	1

NOTES:

- ELECTRICAL TEST: 100% OPEN SHORT MISS WIRE TEST CONTACT RESISTANCE: 2 Ohm MAX INSULATION RESISTANCE: 5 MΩ MIN HI-POT TEST: DC 300V/10 ms PASS 480 Mbps/5V 3A TEST
- MATERIAL:
CONNECTOR A: NICKEL PLATING
BLACK ALUMINUM ALLOY HOUSING
BOOT MATERIAL: 45P BLACK PVC
CONNECTOR B: NICKEL PLATING
BLACK ALUMINUM ALLOY HOUSING,
BOOT MATERIAL: 45P BLACK PVC
- CABLES SHALL BE INDIVIDUALLY PACKAGED IN A SEALED POLYETHYLENE BAG. ONE BAGGED CABLE OF EACH LENGTH SHOWN IN TABULATION BLOCK SHALL BE PLACED IN A LARGER POLYETHYLENE BAG AND SEALED. A LABEL SHOWING THE KIT ITEM NUMBER, ITEM REVISION, AND ITEM DESCRIPTION SHALL BE APPLIED TO THE BAG.

THE INFORMATION CONTAINED IN THIS DRAWING IS THE SOLE PROPERTY OF INFINITE ELECTRONICS, INC. ANY REPRODUCTION IN PART OR WHOLE WITHOUT THE WRITTEN PERMISSION OF INFINITE ELECTRONICS, INC. IS PROHIBITED. THESE COMMODITIES, TECHNOLOGY OR SOFTWARE WERE EXPORTED FROM THE UNITED STATES IN ACCORDANCE WITH THE EXPORT ADMINISTRATION REGULATIONS. DIVERSION CONTRARY TO U.S. LAW PROHIBITED.

UNLESS OTHERWISE SPECIFIED
LEADING DIMENSIONS ARE INCHES
DIMENSIONS IN [] ARE MILLIMETERS

TOLERANCES:
X = ± 2 [5]
.XX = ± 0.02 [0.5]
.XXX = ± 0.005 [0.13]
FRACTIONS
± 1/32
ANGLES ± 1°

CABLE LENGTH TOLERANCES:
≤ 12 [305] = ± 1 [25] / -0
> 12 [305] ≤ 60 [1524] = ± 2 [51] / -0
> 60 [1524] ≤ 120 [3048] = ± 4 [102] / -0
> 120 [3048] ≤ 300 [7620] = ± 6 [152] / -0
> 300 [7620] = +5% / -0

ALL DIMENSIONS ARE FOR REFERENCE ONLY
AND SUBJECT TO CHANGE WITHOUT NOTICE.
UN-DIMENSIONED NON-CRITICAL FEATURES
MAY VARY IN SIZE AND LOCATION
COLORS MAY VARY

Show Me
CABLES

an INFINIT[®] brand

Website: www.ShowMeCables.com
Phone: 1.888.519.9505

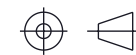

INTERPRET ALL DIMENSIONS AND
TOLERANCES PER ASME Y14.5

SCALE NONE SHEET 1 OF 1

DESCRIPTION
CABLE KIT, USB 3.0, USB-C MALE TO USB-C MALE,
3FT/6FT/10FT

SIZE	CAGE CODE	DRAWN BY	ITEM NO.	REV
A	3SVT8	AKRESOWSKI	SU3-CC-3PK	A

6

5

4

3

2

1