

REVISIONS			
REV.	DESCRIPTION	DATE	APPROVED
A	INITIAL RELEASE	05/16/2022	VCHAN

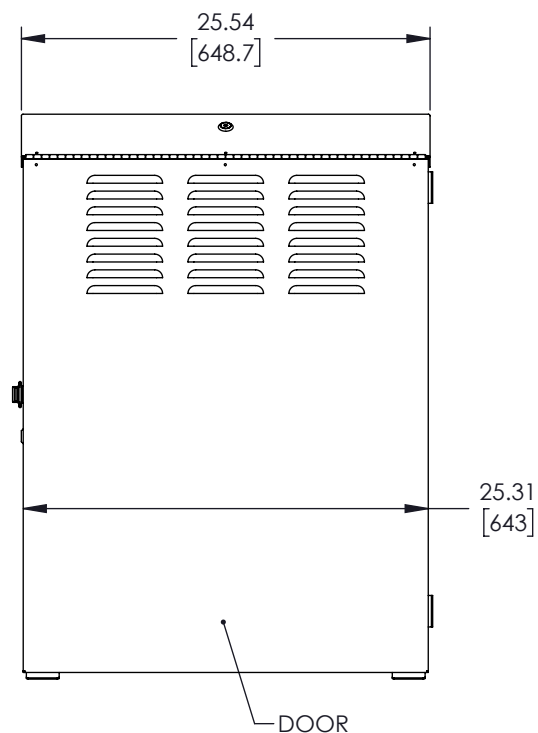
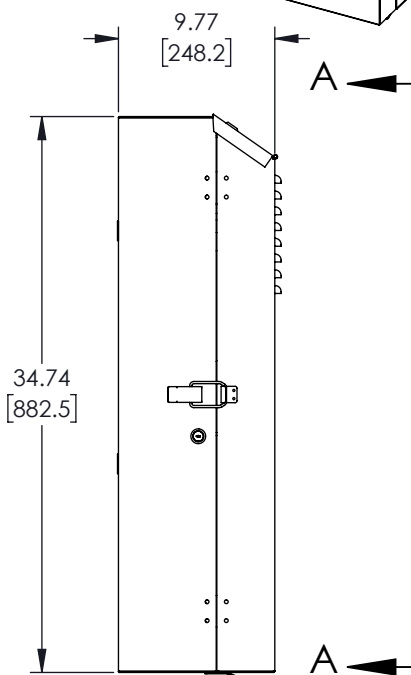
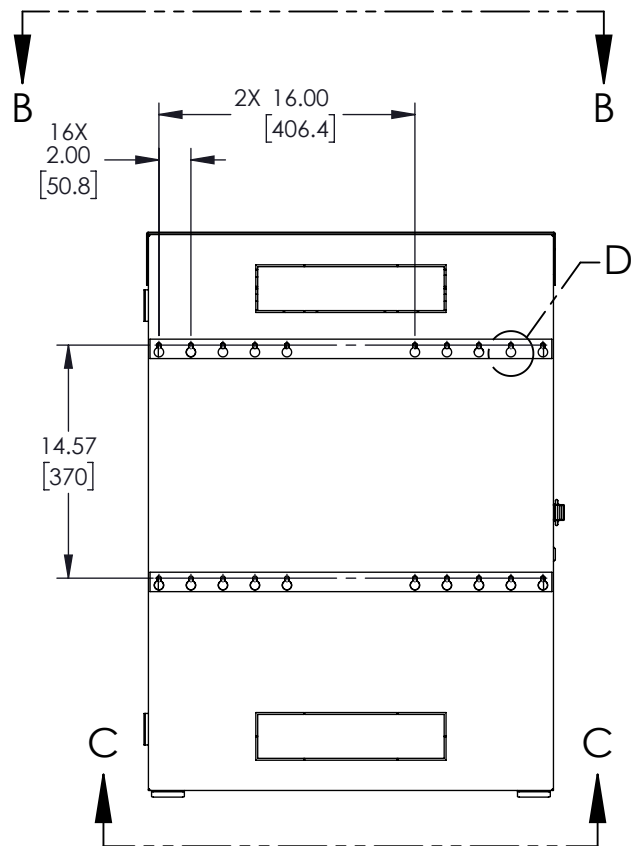

THESE COMMODITIES, TECHNOLOGY OR SOFTWARE WERE EXPORTED FROM THE UNITED STATES IN ACCORDANCE WITH THE EXPORT ADMINISTRATION REGULATIONS. DIVERSION CONTRARY TO U.S. LAW PROHIBITED.

UNLESS OTHERWISE SPECIFIED
LEADING DIMENSIONS ARE INCHES
DIMENSIONS IN [] ARE MILLIMETERS

TOLERANCES:
 X = ± .2 [5.08] FRACTIONS ± 1/32
 .XX = ± .02 [.51] ANGLES ± 1°
 .XXX = ± .005 [.13]

CABLE LENGTH (L) TOLERANCES:
 L ≤ 12 [305] = +1 [25] / -0
 12 [305] < L ≤ 60 [1524] = +2 [51] / -0
 60 [1524] < L ≤ 120 [3048] = +4 [102] / -0
 120 [3048] < L ≤ 300 [7620] = +6 [152] / -0
 300 [7620] < L = +5%L / -0

ALL DIMENSIONS SHOWN
ARE FOR REFERENCE ONLY.

Show Me
CABLES

an INFINIT® brand
115 Chesterfield Industrial Blvd.,
Chesterfield, MO 63005

Phone: 1.888.519.9505 | Fax: 1.888.519.9515
Website: www.ShowMeCables.com
E-mail: CustomerService@ShowMeCables.com

THIRD-ANGLE PROJECTION

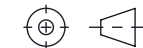

THE INFORMATION AND
DESIGN IN THIS DOCUMENT
IS THE PROPERTY OF
SHOWMECABLES, INC
ALL RIGHTS RESERVED.

SHEET 1 OF 2

SCALE N/A

SIZE	CAGE CODE	DRAWN BY	ITEM NO.	REV
A	3SVT8	DZINN	SMCF5U700	A

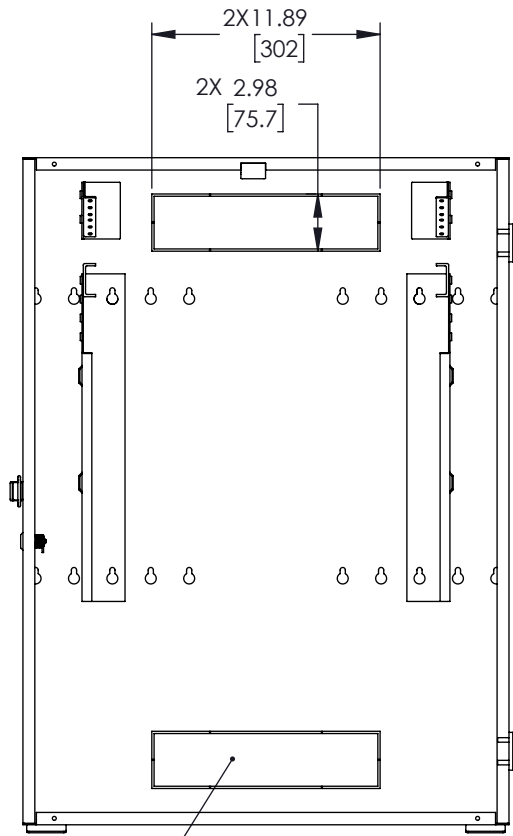

VIEW A-A
POPULATED ENCLOSURE
DOOR NOT SHOWN

2X KNOCK-OUT PLATE

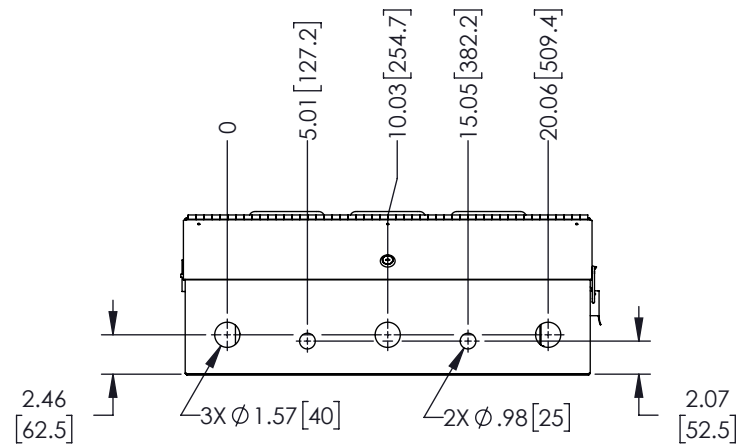
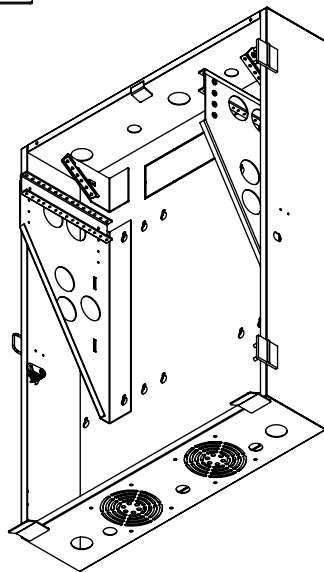

VIEW B-B

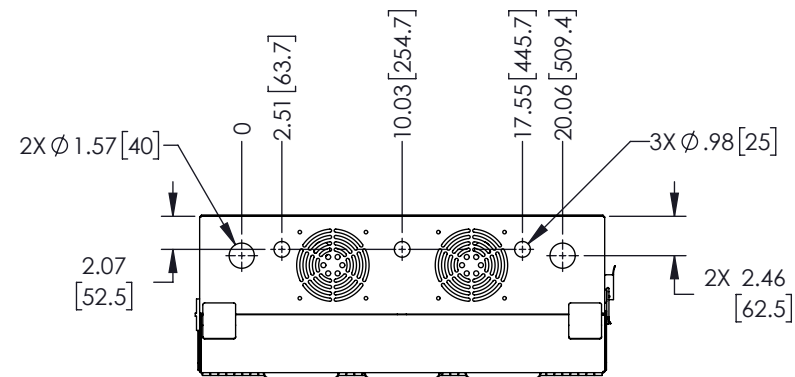

VIEW C-C

THESE COMMODITIES, TECHNOLOGY OR SOFTWARE WERE EXPORTED FROM THE UNITED STATES IN ACCORDANCE WITH THE EXPORT ADMINISTRATION REGULATIONS. DIVERSION CONTRARY TO U.S. LAW PROHIBITED.

UNLESS OTHERWISE SPECIFIED
LEADING DIMENSIONS ARE INCHES
DIMENSIONS IN [] ARE MILLIMETERS

TOLERANCES:
X = ± 2 [5.08] | FRACTIONS ± 1/32
.XX = ± 0.02 [0.51] | ANGLES ± 1°
XXX = ± 0.005 [0.13]

CABLE LENGTH (L) TOLERANCES:
L ≤ 12 [305] = +1 [25] / -0
12 [305] < L ≤ 60 [1524] = +2 [51] / -0
60 [1524] < L ≤ 120 [3048] = +4 [102] / -0
120 [3048] < L ≤ 300 [7620] = +6 [152] / -0
300 [7620] < L = +5%L / -0

ALL DIMENSIONS SHOWN
ARE FOR REFERENCE ONLY.

Show Me
CABLES

an INFINIT® brand
115 Chesterfield Industrial Blvd.,
Chesterfield, MO 63005

Phone: 1.888.519.9505 | Fax: 1.888.519.9515
Website: www.ShowMeCables.com
E-mail: CustomerService@ShowMeCables.com

THIRD-ANGLE PROJECTION

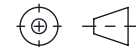

THE INFORMATION AND
DESIGN IN THIS DOCUMENT
IS THE PROPERTY OF
SHOWMECABLES, INC
ALL RIGHTS RESERVED.

SHEET 2 OF 2

SCALE N/A

SIZE A	CAGE CODE 3SVT8	DRAWN BY DZINN	ITEM NO. SMCF5U700	REV A
-----------	--------------------	-------------------	-----------------------	----------