

REVISIONS			
REV.	DESCRIPTION	DATE	APPROVED
A	INITIAL RELEASE	05/23/2022	VCHAN

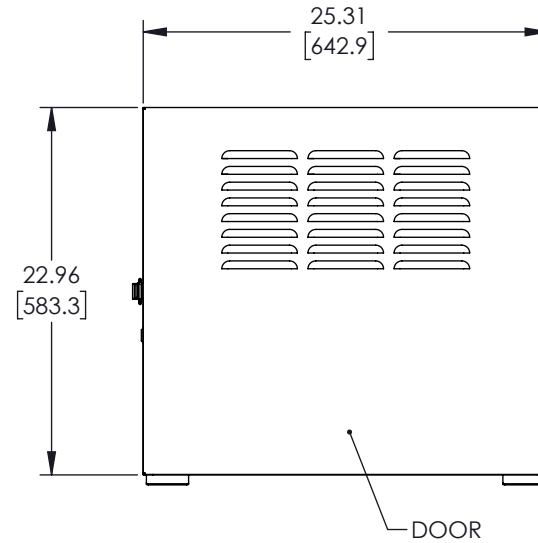
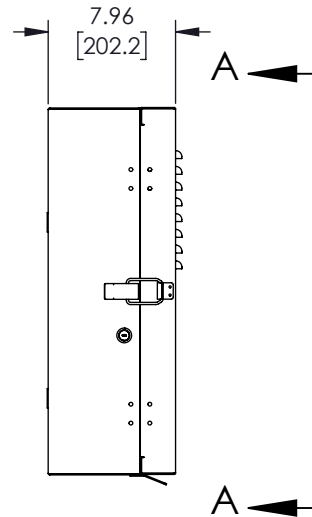
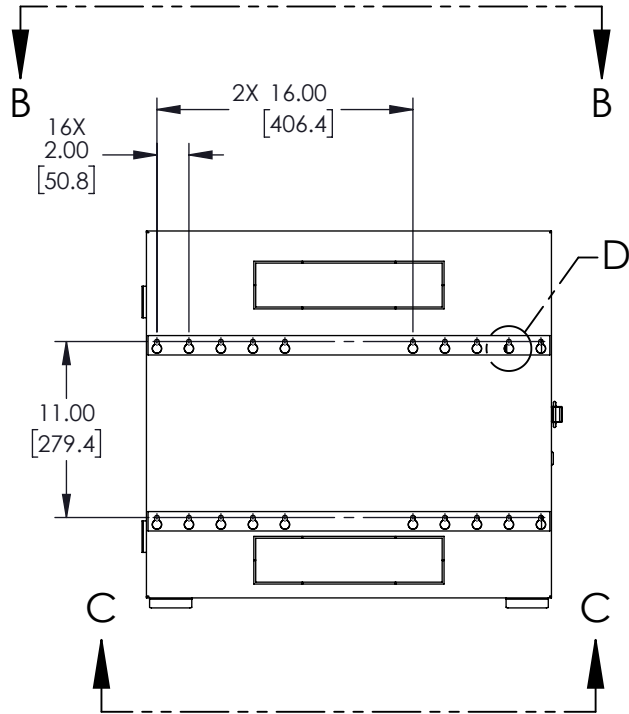

THESE COMMODITIES, TECHNOLOGY OR SOFTWARE WERE EXPORTED FROM THE UNITED STATES IN ACCORDANCE WITH THE EXPORT ADMINISTRATION REGULATIONS. DIVERSION CONTRARY TO U.S. LAW PROHIBITED.

UNLESS OTHERWISE SPECIFIED  
LEADING DIMENSIONS ARE INCHES  
DIMENSIONS IN [ ] ARE MILLIMETERS

TOLERANCES:  
 X = ± .2 [5.08] | FRACTIONS ± 1/32  
 .XX = ± .02 [.51] | ANGLES ± 1°  
 .XXX = ± .005 [.13]

CABLE LENGTH (L) TOLERANCES:  
 L ≤ 12 [305] = +1 [25] / -0  
 12 [305] < L ≤ 60 [1524] = +2 [51] / -0  
 60 [1524] < L ≤ 120 [3048] = +4 [102] / -0  
 120 [3048] < L ≤ 300 [7620] = +6 [152] / -0  
 300 [7620] < L = +5%L / -0

ALL DIMENSIONS SHOWN  
ARE FOR REFERENCE ONLY.

**Show Me**  
CABLES

an INFINIT<sup>®</sup> brand  
115 Chesterfield Industrial Blvd.,  
Chesterfield, MO 63005

Phone: 1.888.519.9505 | Fax: 1.888.519.9515  
Website: [www.ShowMeCables.com](http://www.ShowMeCables.com)  
E-mail: [CustomerService@ShowMeCables.com](mailto:CustomerService@ShowMeCables.com)

THIRD-ANGLE PROJECTION

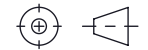

THE INFORMATION AND  
DESIGN IN THIS DOCUMENT  
IS THE PROPERTY OF  
SHOWMECABLES, INC  
ALL RIGHTS RESERVED.

SHEET 1 OF 2

SCALE N/A

SIZE	CAGE CODE	DRAWN BY	ITEM NO.	REV
A	3SVT8	DZINN	SMCF4U400	A

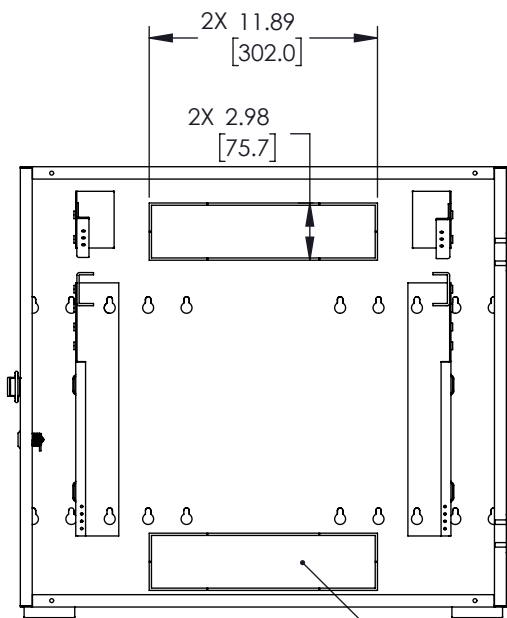

2X KNOCK-OUT PLATE

VIEW A-A  
POPULATED ENCLOSURE  
DOOR NOT SHOWN

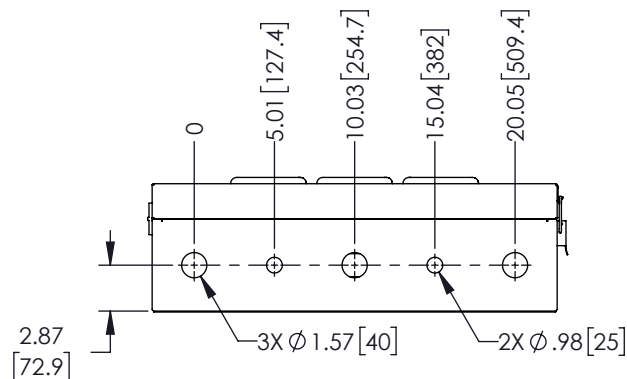
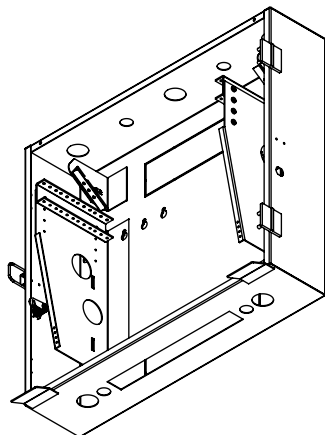

VIEW B-B

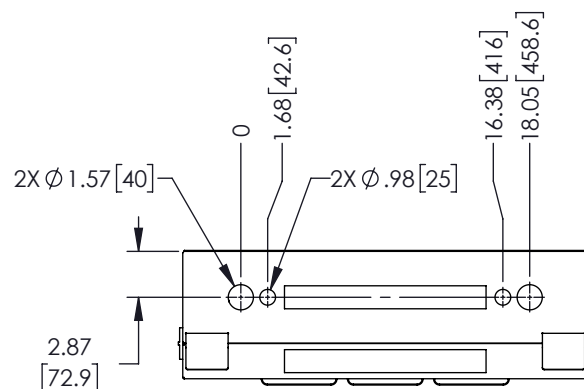

VIEW C-C

THESE COMMODITIES, TECHNOLOGY OR SOFTWARE WERE EXPORTED FROM THE UNITED STATES IN ACCORDANCE WITH THE EXPORT ADMINISTRATION REGULATIONS. DIVERSION CONTRARY TO U.S. LAW PROHIBITED.

UNLESS OTHERWISE SPECIFIED  
LEADING DIMENSIONS ARE INCHES  
DIMENSIONS IN [ ] ARE MILLIMETERS

TOLERANCES:

X = ± .2 [ .508] | FRACTIONS ± 1/32  
.XX = ± .02 [ .51] | ANGLES ± 1°  
XXX = ± .005 [ .13]

CABLE LENGTH (L) TOLERANCES:

L ≤ 12 [305] = +1 [25] / -0  
12 [305] < L ≤ 60 [1524] = +2 [51] / -0  
60 [1524] < L ≤ 120 [3048] = +4 [102] / -0  
120 [3048] < L ≤ 300 [7620] = +6 [152] / -0  
300 [7620] < L = +5%L / -0

ALL DIMENSIONS SHOWN  
ARE FOR REFERENCE ONLY.

**Show Me**  
CABLES

an INFINIT® brand  
115 Chesterfield Industrial Blvd.,  
Chesterfield, MO 63005

Phone: 1.888.519.9505 | Fax: 1.888.519.9515  
Website: www.ShowMeCables.com  
E-mail: CustomerService@ShowMeCables.com

THIRD-ANGLE PROJECTION



THE INFORMATION AND  
DESIGN IN THIS DOCUMENT  
IS THE PROPERTY OF  
SHOWMECABLES, INC  
ALL RIGHTS RESERVED.

SHEET 2 OF 2

SCALE N/A

SIZE A	CAGE CODE 3SVT8	DRAWN BY DZINN	ITEM NO. SMCF4U400	REV A
-----------	--------------------	-------------------	-----------------------	----------