

6

5

4

3

2

1

| REVISION |     |                 |            |            |           |
|----------|-----|-----------------|------------|------------|-----------|
| ZONE     | REV | DESCRIPTION     | DATE       | CHANGED BY | APPROVED  |
|          | A   | INITIAL RELEASE | 01/22/2024 | KGLEBOVA   | THOUGHTON |

F

F

E

E

D

D

C

C

B

B

A

A

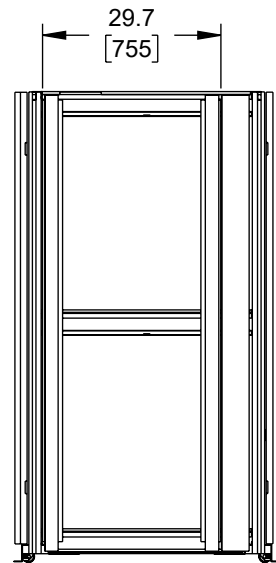
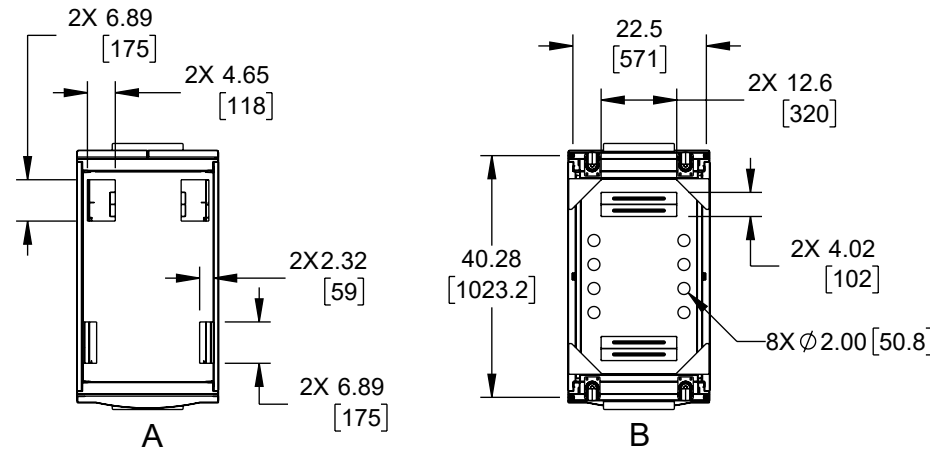
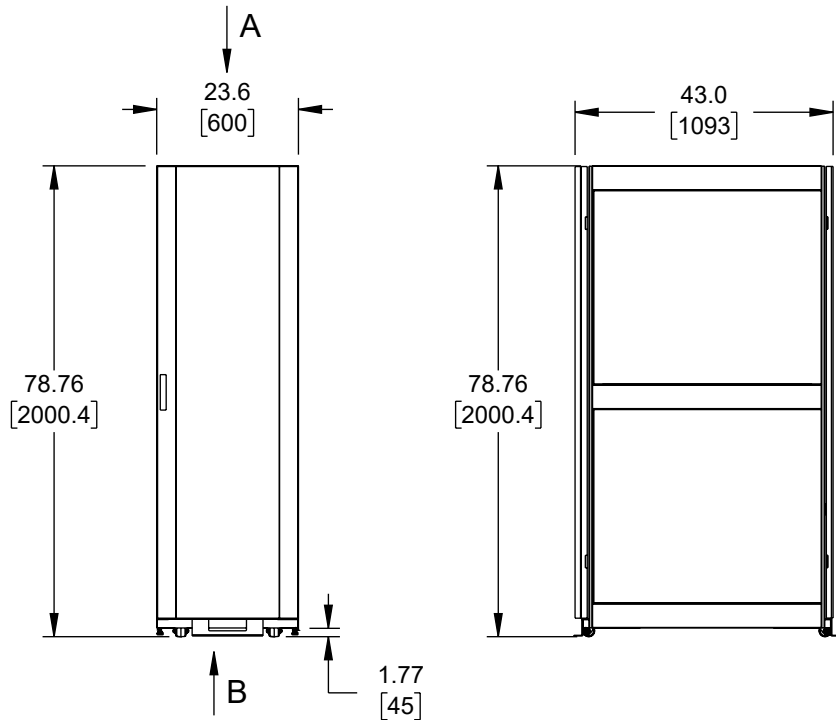

MAX EQUIPMENT MNT DEPTH  
(WITH CABLE MANAGEMENT RAIL)

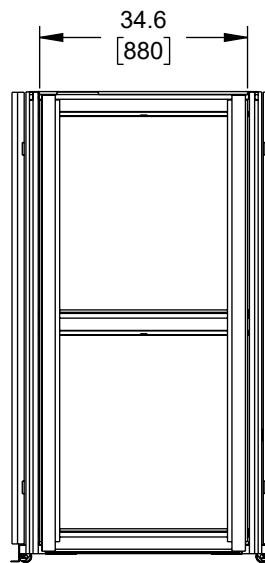

MAX EQUIPMENT MNT DEPTH  
(WITHOUT CABLE MANAGEMENT RAIL)

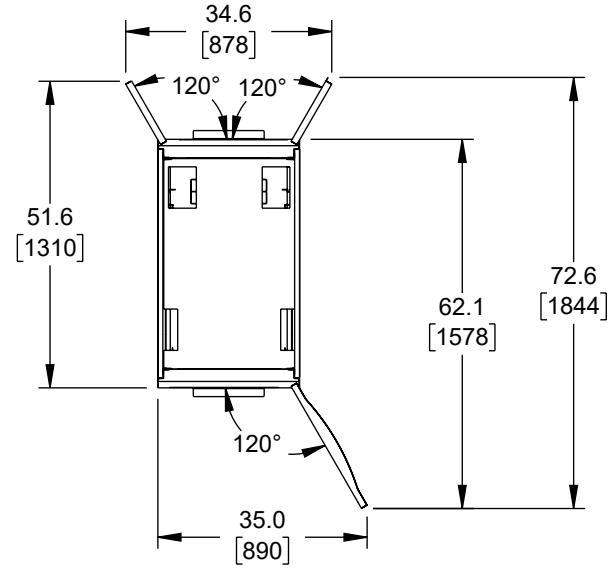

TOP VIEW  
DOORS FULLY OPENED

THE INFORMATION CONTAINED IN THIS DRAWING IS THE SOLE PROPERTY OF INFINITE ELECTRONICS, INC. ANY REPRODUCTION IN PART OR WHOLE WITHOUT THE WRITTEN PERMISSION OF INFINITE ELECTRONICS, INC. IS PROHIBITED. THESE COMMODITIES, TECHNOLOGY OR SOFTWARE WERE EXPORTED FROM THE UNITED STATES IN ACCORDANCE WITH THE EXPORT ADMINISTRATION REGULATIONS. DIVERSION CONTRARY TO U.S. LAW PROHIBITED.

UNLESS OTHERWISE SPECIFIED LEADING DIMENSIONS ARE INCHES DIMENSIONS IN [ ] ARE MILLIMETERS

TOLERANCES:

|                     |                  |
|---------------------|------------------|
| .X = ±.2 [5]        | FRACTIONS ± 1/32 |
| .XX = ±.02 [0.5]    | ANGLES ± 1°      |
| .XXX = ±.005 [0.13] |                  |

CABLE LENGTH TOLERANCES:

|                          |                 |
|--------------------------|-----------------|
| ≤12 [305]                | = +1 [25] / -0  |
| >12 [305] ≤ 60 [1524]    | = +2 [51] / -0  |
| >60 [1524] ≤ 120 [3048]  | = +4 [102] / -0 |
| >120 [3048] ≤ 300 [7620] | = +6 [152] / -0 |
| >300 [7620]              | = +5% / -0      |

ALL DIMENSIONS ARE FOR REFERENCE ONLY AND SUBJECT TO CHANGE WITHOUT NOTICE. UN-DIMENSIONED/NON-CRITICAL FEATURES MAY VARY IN SIZE AND LOCATION. COLORS MAY VARY.



Website: [www.ShowMeCables.com](http://www.ShowMeCables.com)  
Phone: 1.888.519.9505

|  |        |
|--|--------|
|  |        |
| INTERPRET ALL DIMENSIONS AND TOLERANCES PER ASME Y14.5 |        |
| SCALE  | SHEET  |
| NONE   | 1 OF 1 |

DESCRIPTION  
42U SERVER RACK CABINET (WHITE), 1000MM DEPTH, PERF. FRONT DOOR AND REAR FRENCH DOORS, CABLE MGT. TOP

| SIZE | CAGE CODE | DRAWN BY | ITEM NO.             | REV |
|------|-----------|----------|----------------------|-----|
| A    | 3SVT8     | KGLEBOVA | SM42USRC1000PDFRCM-W | A   |

6

5

4

3

2

1