

6

5

4

3

2

1

REVISION					
ZONE	REV	DESCRIPTION	DATE	CHANGED BY	APPROVED
	A	INITIAL RELEASE	01/19/2024	KGLEBOVA	THOUGHTON

F

F

E

E

D

D

C

C

B

B

A

A

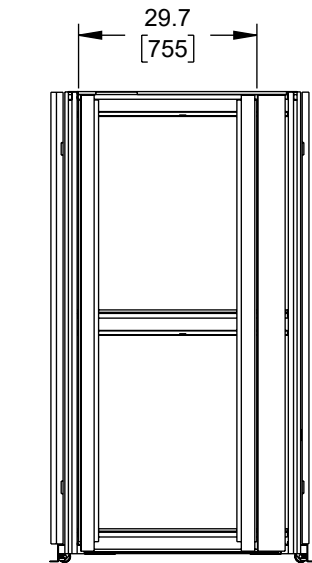
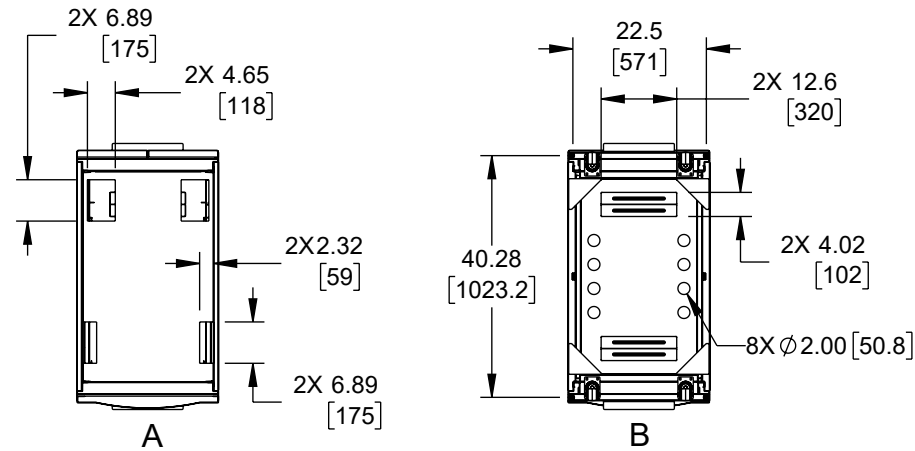
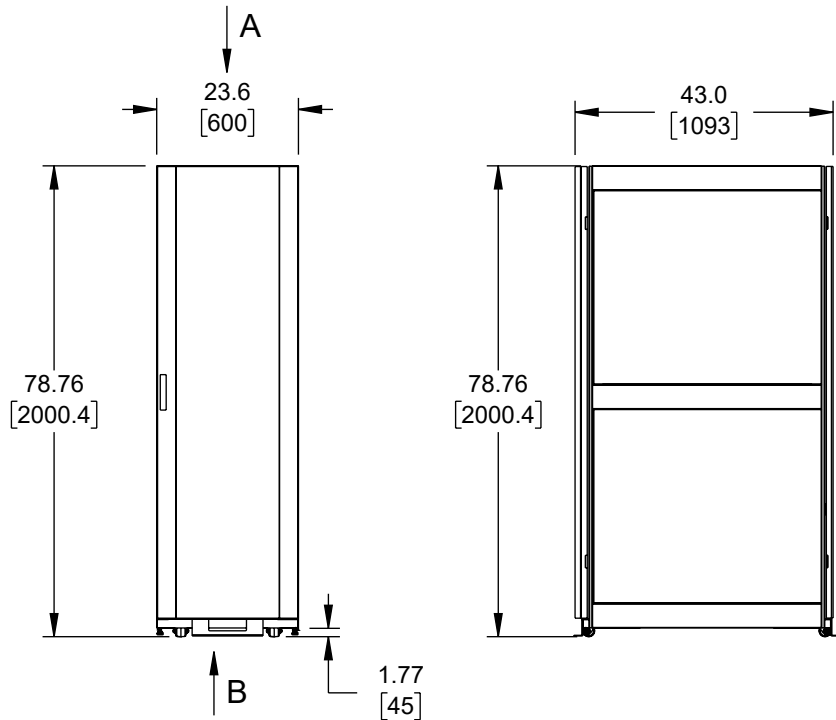

1.77 [45]

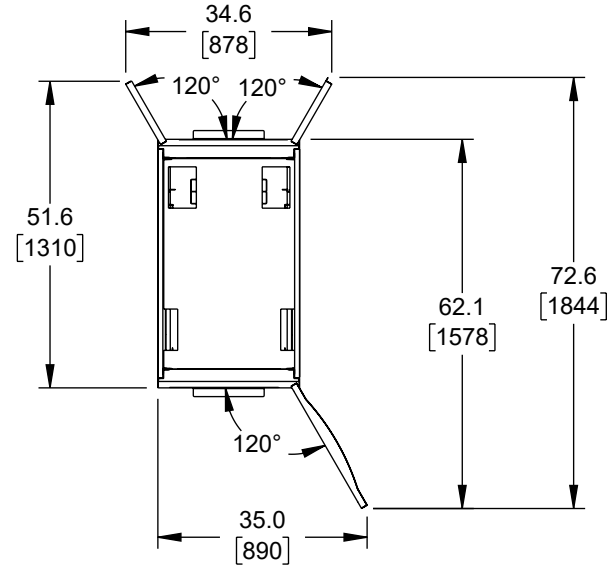
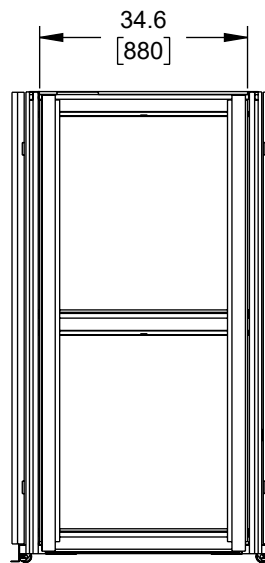

TOP VIEW
DOORS FULLY OPENED

MAX EQUIPMENT MNT DEPTH
(WITH CABLE MANAGEMENT RAIL)

MAX EQUIPMENT MNT DEPTH
(WITHOUT CABLE MANAGEMENT RAIL)

THE INFORMATION CONTAINED IN THIS DRAWING IS THE SOLE PROPERTY OF INFINITE ELECTRONICS, INC. ANY REPRODUCTION IN PART OR WHOLE WITHOUT THE WRITTEN PERMISSION OF INFINITE ELECTRONICS, INC. IS PROHIBITED. THESE COMMODITIES, TECHNOLOGY OR SOFTWARE WERE EXPORTED FROM THE UNITED STATES IN ACCORDANCE WITH THE EXPORT ADMINISTRATION REGULATIONS. DIVERSION CONTRARY TO U.S. LAW PROHIBITED.

UNLESS OTHERWISE SPECIFIED LEADING DIMENSIONS ARE INCHES DIMENSIONS IN [] ARE MILLIMETERS

TOLERANCES:
 .X = ±.2 [5] FRACTIONS ± 1/32
 .XX = ±.02 [0.5] ANGLES ± 1°
 .XXX = ±.005 [0.13]

CABLE LENGTH TOLERANCES:
 ≤12 [305] = +1 [25] / -0
 >12 [305] ≤ 60 [1524] = +2 [51] / -0
 >60 [1524] ≤ 120 [3048] = +4 [102] / -0
 >120 [3048] ≤ 300 [7620] = +6 [152] / -0
 >300 [7620] = +5% / -0

ALL DIMENSIONS ARE FOR REFERENCE ONLY AND SUBJECT TO CHANGE WITHOUT NOTICE. UN-DIMENSIONED/NON-CRITICAL FEATURES MAY VARY IN SIZE AND LOCATION. COLORS MAY VARY.

Show Me
CABLES
an INFINIT[®] brand

Website: www.ShowMeCables.com
Phone: 1.888.519.9505

INTERPRET ALL DIMENSIONS AND TOLERANCES PER ASME Y14.5

SCALE: NONE SHEET: 1 OF 1

DESCRIPTION
42U SERVER RACK CABINET (WHITE), 1000MM DEPTH, GLASS FRONT DOOR AND PERF. REAR FRENCH DOORS, CABLE MGT. TOP

SIZE	CAGE CODE	DRAWN BY	ITEM NO.	REV
A	3SVT8	KGLEBOVA	SM42USRC1000GDFRCM-W	A

6

5

4

3

2

1