

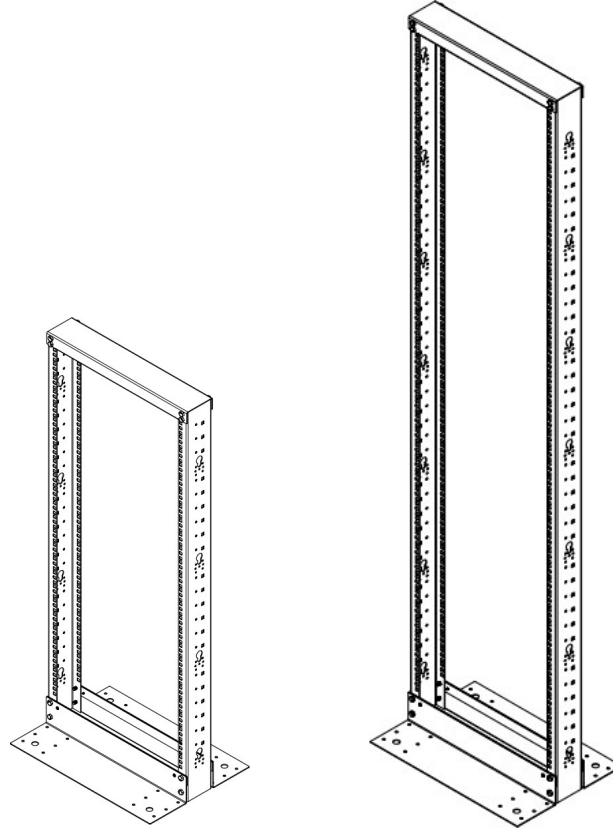





## 2 Post Open Frame Rack



Keep this information for further reference:

-  Thank you for purchasing an SMC product.
-  Please examine the product for any damaged parts. If any part is damaged or missing, contact SMC for assistance. Do not attempt to install or use product if it has been damaged.
-  During installation, lay product contents on cardboard or other protective surface to avoid any damage.
-  Improper installation or use of this product could result in damage to the product, other equipment, or personal injury. It is recommended that installation be performed by a qualified installer. SMC cannot be held responsible for damage to equipment or personal injury resulting from improper use or installation of product. If product is intended to store/mount equipment, please ensure the equipment stored/mounted does not exceed the specified weight capacity. Install the heaviest equipment first and install it at the bottom of the rack. Install equipment starting from the bottom of the rack and move upward.
-  **Limitations of Liability:** In no event will SMC be liable for any damages, whether direct or indirect, special, punitive, incidental or consequential damages (including, but not limited to, lost profits or revenue, loss of use, lost business opportunities or loss of goodwill) or for the costs of procuring substitute products, arising out of or in connection with the use of the product, whether such liability arises from any claim based upon contract, warranty, tort (including negligence), product liability or otherwise, whether or not seller has been advised of the possibility of such loss or damage. In no event will the seller's total cumulative liability, from all causes of action and all theories of liability, exceed the total amounts actually paid to seller by customer under the order that gives rise to any liability hereunder.

 Parts Identification

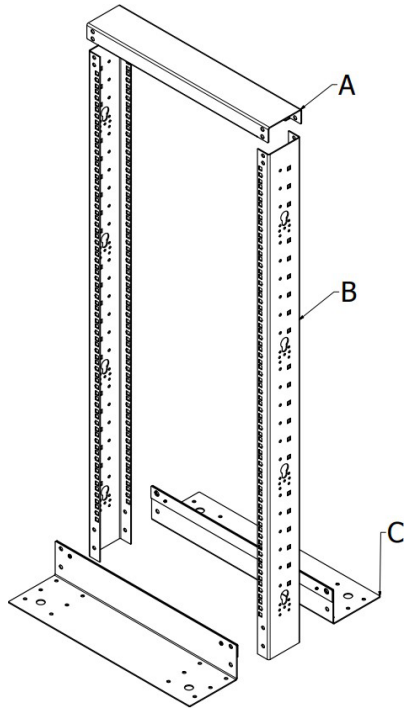

- A** Top Bracket (1)
- B** Vertical Rack Rail (2)
- C** Base Bracket (2)

**D**

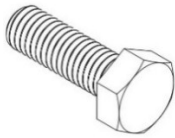

M8 x 16mm Hex Bolts (x16)

**E**



M6 Mounting Screws  
25U(x20) 45U(x40)

**F**

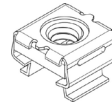

Hook Mounting Screws  
25U (x20) 45U (x40)

**G**



M6 Washer  
25U(x20) 45U (x40)

**H**



Hook Mounting Screws  
25U (x8) 45U (x14)

**I**

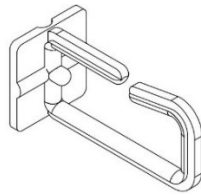

Cable Management Hooks (8)  
25U (x8) 45U (x14)

**J**

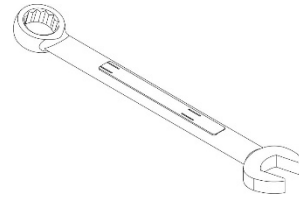

M8 Wrench (x1)

 Rack Assembly

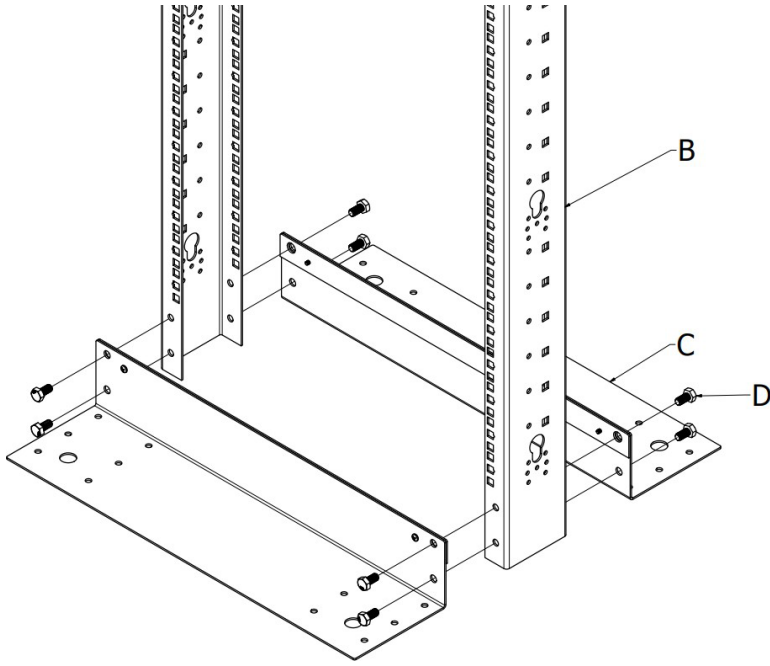

Connect Vertical Rack Rails (B) to the Base Brackets (C) with 8 of the M8 x 16mm Hex Bolts (D) using M8 Wrench (J).

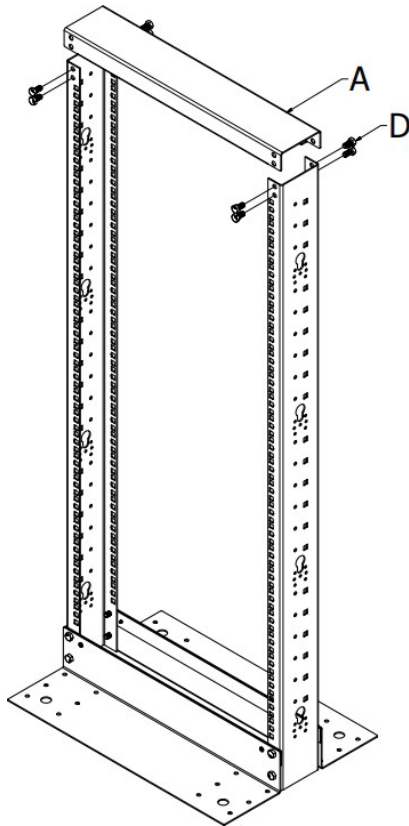

Connect Top Brackets (A) to the combined Vertical Rack Rails with 8 of the M8 x 16mm Hex Bolts (D) using M8 Wrench (J).

## Optional Cable Management Hooks

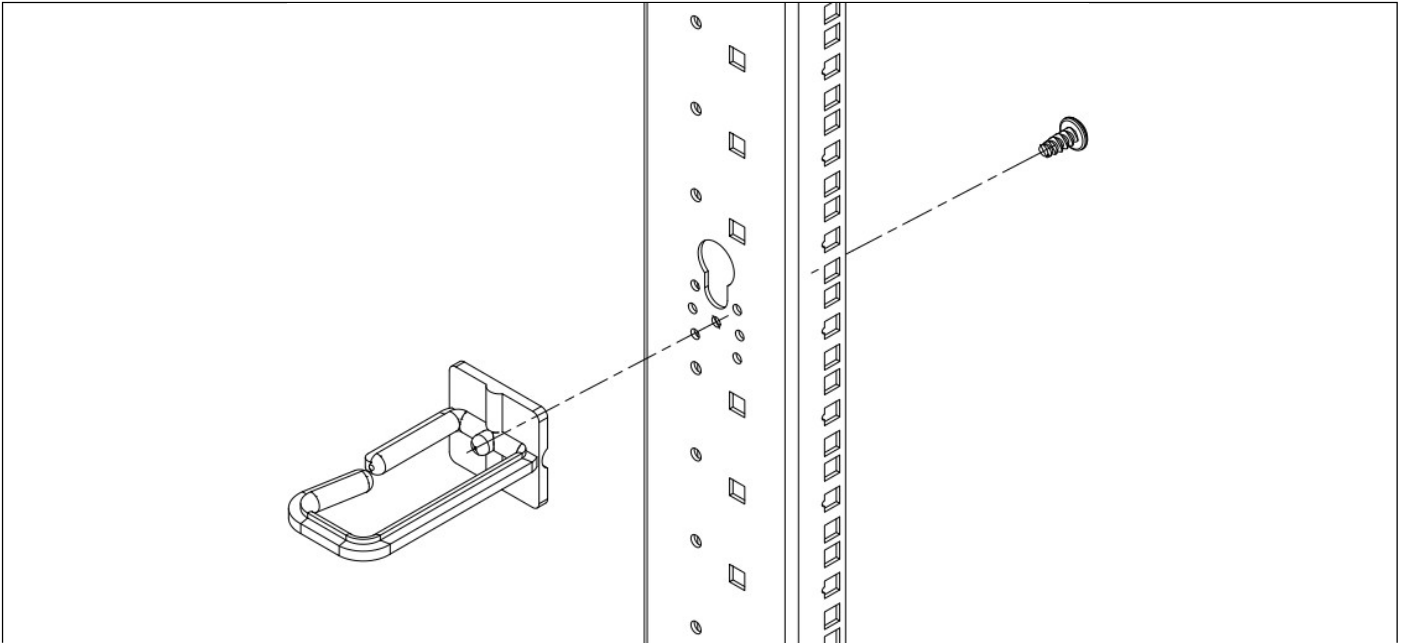

Optional: Fasten the included cable management hooks (I) to the vertical rack rails with the included screws (H) using a Phillips Screwdriver (not included).

## Equipment Installation

### 1 Rack Unit

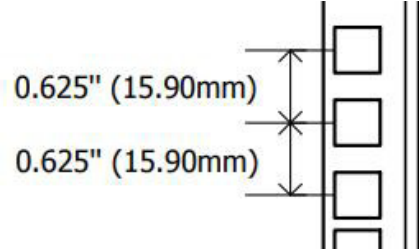
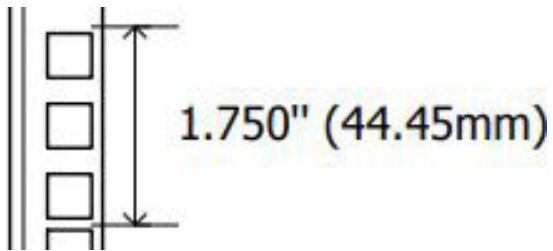

## Squared Hole Mounting

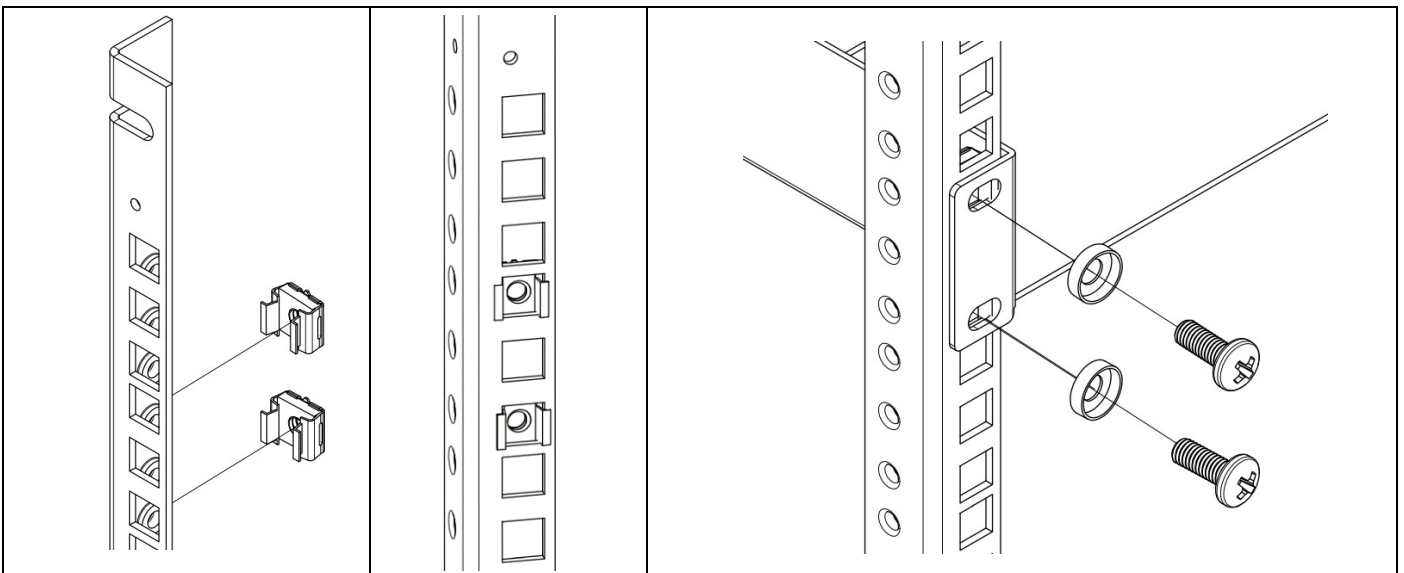

- 1.** Locate the numbered square openings in the mounting rails where you plan to install your equipment. You will install cage nuts (included) into the square openings in order to provide an attachment point for the mounting screws (included).  
Note: Consult your equipment documentation to determine how many cage nuts will be required and where they will need to be installed.
  - a.** From the inside of the mounting rail, insert one of the flanges of the cage nut through the square opening. Press it against the side of the square opening. Each flange should engage one side of the square opening, not the top or bottom.
  - b.** Compress the cage nut at the sides slightly to allow the remaining flange to fit through the square opening. When the cage nut is properly installed, both flanges will protrude through the square opening and will be visible on the outer surface of the mounting rail. Repeat steps 1a and 1b until all required cage nuts are installed.
- 2.** After installing the required cage nuts, use the included black mounting screws and cup washers to secure your equipment to the rack rail. Place the cup washers between the screws and the equipment mounting brackets.