

# Wall Mount Vertical Hinged Bracket

## PRODUCT SPECIFICATION

### Package includes:

- A. Main Body, 1 pc
- B. Base, 1 pc
- C. Gate Assembly, 1 pc
- D. #10-32 x 3/8" Thread Forming Screw, 4 pcs
- E. 5/16-18 UNC Wing Nut, 2 pcs
- F. 5/16-18 UNC Nylok Hex Nut, 4 pcs
- G. Nylon Washer, 4 pcs
- H. #12-24 x 5/8" Pan Head, Pilot Point Machine Screw, 31 pcs

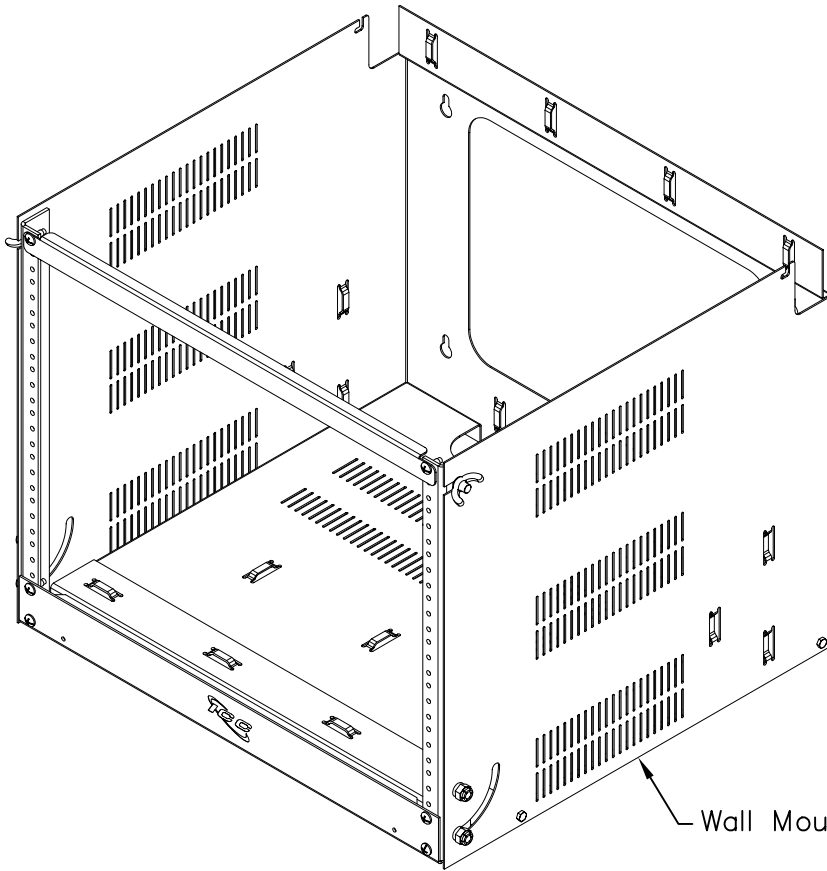

Wall Mount Vertical Hinged Bracket

### Features and Benefits:

- Designed with black textured powder coated, durable steel construction
- Ideal for installing voice and data equipment such as patch panels, active components, and cable management products creating a neat structured and organized cabling system
- Allows easy access during and after the installation and is ideal for installations with space limitations prohibiting the use of floor mount racks
- Available in 6 rack mount space (RMS) to support 40 pounds of equipment and 8 rack mount space (RMS) to support 60 pounds of equipment
- 8 rack mount space (RMS) version is available in 12" and 18" depths
- Used with ICC rack mount products

### BRACKET, WALL MOUNT VERTICAL HINGED

ITEM NO. ICCMSVHBXX

REV. B

DWG NO. PSCMSVHB00

PAGE NO. 1



CUSTOMER CARE / TECHNICAL SUPPORT \* CSR@ICC.COM / 888-ASK-4-ICC (275-4422) \* 14700 Alondra Blvd., La Mirada, CA 90638 \* www.icc.com

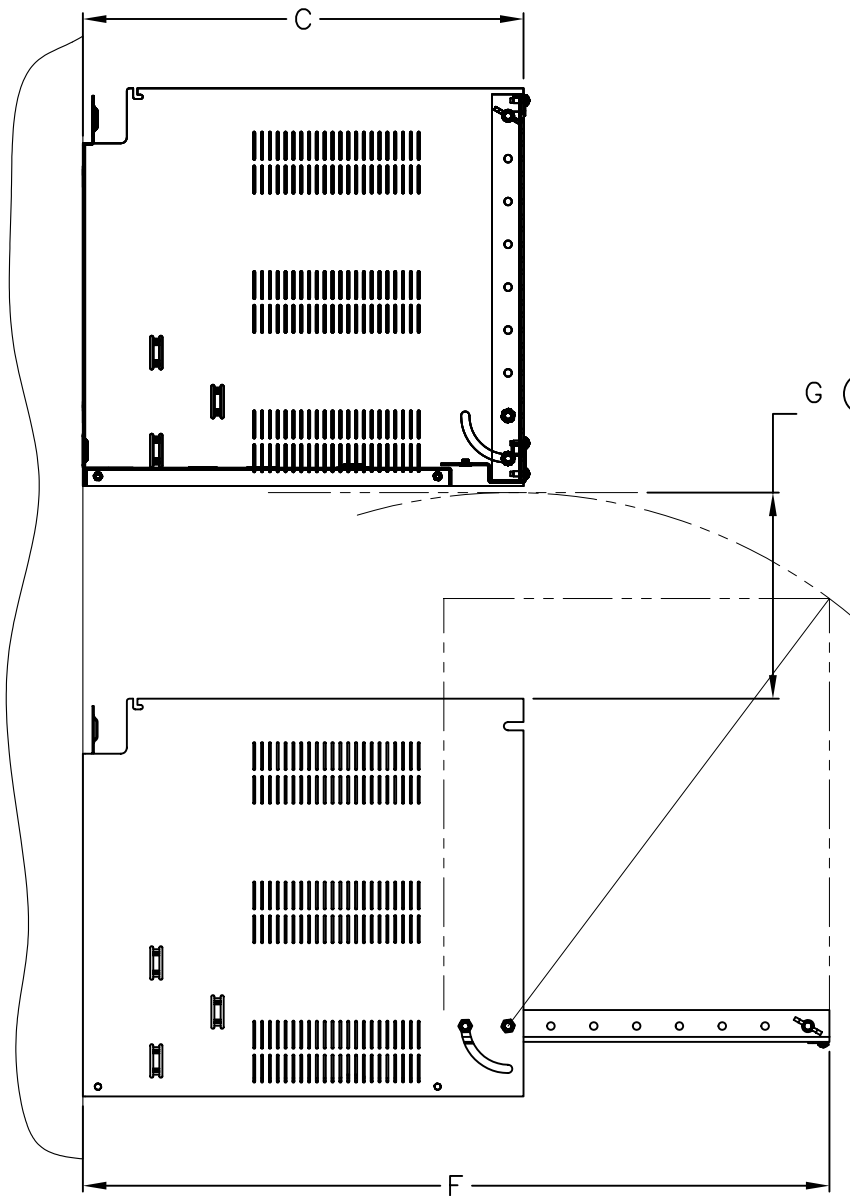

G (MINIMUM RECOMMENDED CLEARANCE BETWEEN BRACKETS WITH MAXIMUM EQUIPMENT DEPTH)

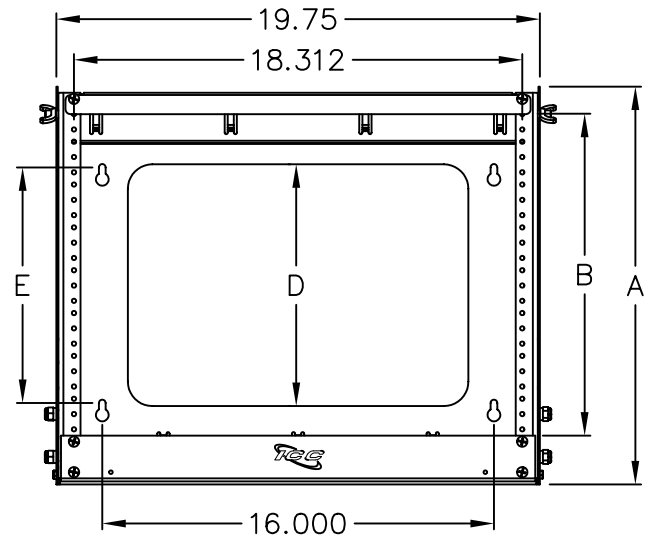

**NOTE: UNLESS OTHERWISE SPECIFIED**

1. MATERIAL:
  - A. MAIN BODY: 16 GA CRS
  - B. BASE: 16 GA CRS
  - C. GATE ASSEMBLY:
    - TOP SUPPORT: 16 GA CRS
    - BOTTOM SUPPORT: 14 GA CRS
    - SIDE RAILS: 11 GA CRS
2. SURFACE FINISH: BLACK TEXTURED POWDER COAT

ITEM NO.	A	B	C	D	E	F	G	SHIPPING WEIGHT	WEIGHT CAPACITY
ICCMSVHB06	12.75 "	9.63 "	12.00 "	6.38 "	6.13 "	21.00 "	5.00 "	19 LBS	40 LBS
ICCMSVHB08	16.25 "	13.13 "	12.00 "	9.88 "	9.63 "	24.50 "	4.00 "	21 LBS	60 LBS
ICCMSVHB18	16.25 "	13.13 "	18.00 "	9.88 "	9.63 "	30.50 "	8.35 "	27 LBS	60 LBS

<b>BRACKET, WALL MOUNT VERTICAL HINGED</b>		 <i>PremiumProducts</i> <i>ProvenPerformance</i> <i>CompetitivePrices</i>	
ITEM NO.	ICCMSVHBXX		REV. B
DWG NO.	PSCMSVHB00		PAGE NO. 2

CUSTOMER CARE / TECHNICAL SUPPORT \* CSR@ICC.COM / 888-ASK-4-ICC (275-4422) \* 14700 Alondra Blvd., La Mirada, CA 90638 \* www.icc.com