

REVISIONS			
REV.	DESCRIPTION	DATE	APPROVED
A	INITIAL RELEASE	2/1/22	DREBECK

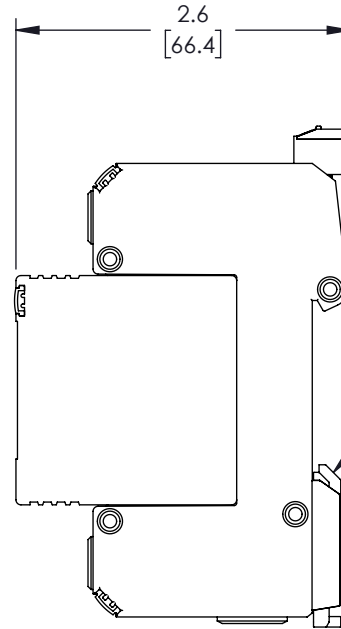
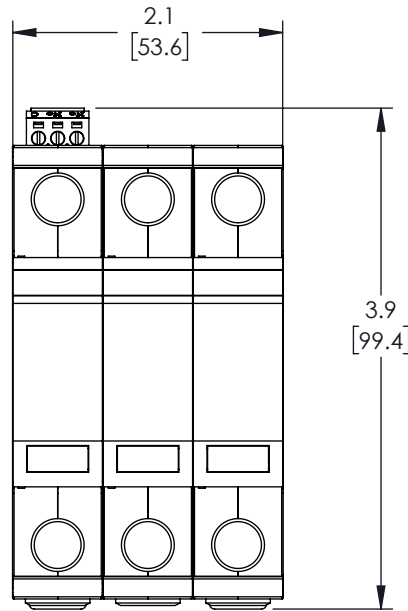

3-POS SCREW TERMINAL  
FOR REMOTE SUPPRESSION  
STATUS WIRING

COMPRESSION LUGS  
FOR SERVICE WIRING

DIN-FOOT  
FOR MOUNTING

VISUAL SUPPRESSION  
STATUS INDICATORS

REPLACEABLE SURGE MODULES

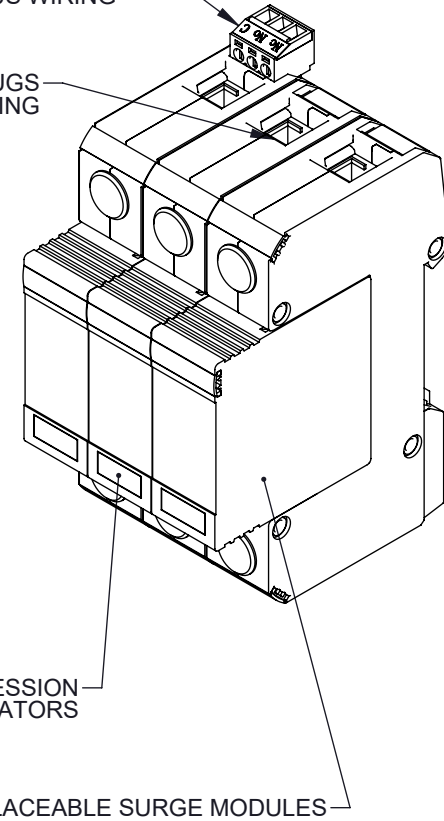

THESE COMMODITIES, TECHNOLOGY OR SOFTWARE WERE EXPORTED FROM THE UNITED STATES IN ACCORDANCE WITH THE EXPORT ADMINISTRATION REGULATIONS. DIVERSION CONTRARY TO U.S. LAW PROHIBITED.

UNLESS OTHERWISE SPECIFIED  
LEADING DIMENSIONS ARE INCHES  
DIMENSIONS IN [ ] ARE MILLIMETERS

**TOLERANCES:**

X = ± .2 [5.08]      FRACTIONS  
.XX = ± .02 [.51]      ± 1/32  
XXX = ± .005 [.13]      ANGLES ± 1°

**CABLE LENGTH (L) TOLERANCES:**

L ≤ 12 [305] = +1 [25] / -0  
12 [305] < L ≤ 60 [1524] = +2 [51] / -0  
60 [1524] < L ≤ 120 [3048] = +4 [102] / -0  
120 [3048] < L ≤ 300 [7620] = +6 [152] / -0  
300 [7620] < L = +5%L / -0

ALL DIMENSIONS SHOWN  
ARE FOR REFERENCE ONLY.

**L-com**<sup>TM</sup>  
an INFINIT<sup>®</sup> brand

50 High Street, West Mill, 3rd Floor, Suite #30  
North Andover, MA 01845 USA.

Phone: 1.800.341.5266 | 1.978.682.6936  
Fax: 1.978.689.9484

Website: www.L-com.com  
E-mail: CustomerService@L-com.com

THIRD-ANGLE PROJECTION

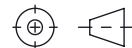

THE INFORMATION AND  
DESIGN IN THIS DOCUMENT  
IS THE PROPERTY OF  
L-COM GLOBAL CONNECTIVITY.  
ALL RIGHTS RESERVED.

SHEET 1 OF 1

SCALE N/A

SIZE	CAGE CODE	DRAWN BY	ITEM NO.	REV
A	43321	DMAY	I2R-T2DC-600Y-LC	A