

THE INFORMATION CONTAINED IN THIS DRAWING IS THE SOLE PROPERTY OF L-COM, INC. ANY REPRODUCTION IN PART OR WHOLE WITHOUT THE WRITTEN PERMISSION OF L-COM, INC. IS PROHIBITED.

REVISIONS			
REV	DESCRIPTION	DATE	APPROVED
A	INITIAL RELEASE	05/18/2022	PHOSPODAR

FIBER TYPE	MULTIMODE, OM2, DUPLEX, RISER	
CORE DIAMETER	50 μm	
CLADDING DIAMETER	125 μm	
BUFFER	0.87 ±0.05	

WAVELENGTH:	850/1300nm FIBER TYPE	850/1300nm MAXIMUM
ATTENUATION	3.0/1.0 dB/km	3.5/1.5 dB/km
OFL BANDWIDTH (MHz.km)	≥500/500	

MAX. TENSILE STRENGTH (N)	
SHORT TERM	200
LONG TERM	100

MIN. BEND RADIUS (mm)	
DYNAMIC	20X DIA.
STATIC	10X DIA.

MAX. CRUSH RESISTANCE (N/100mm)	
SHORT TERM	500
LONG TERM	100

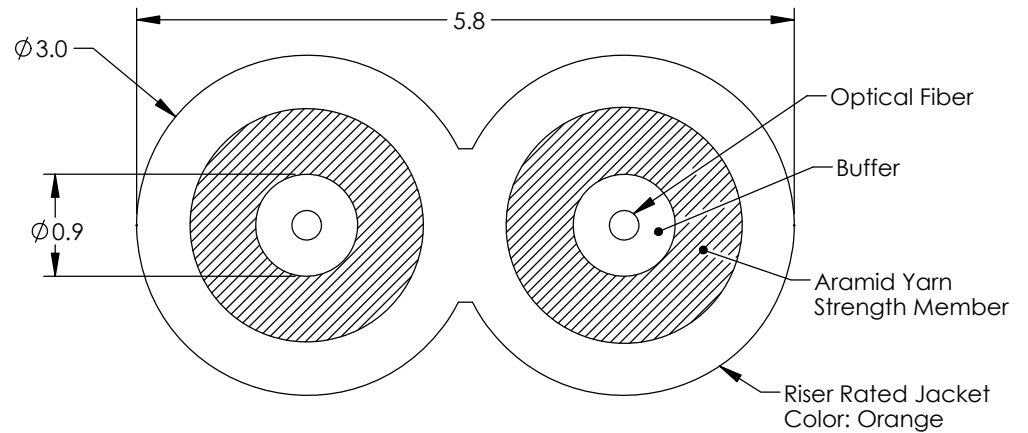

ALL DIMENSIONS IN mm, DRAWING NOT TO SCALE

NOTES:

- BULK CABLE SHALL BE INDIVIDUALLY PACKAGED IN ACCORDANCE WITH L-COM SPECIFICATION PS-0031.

REGULATORY COMPLIANCE:

EU RoHS DIRECTIVE (MOST RECENT RELEASED VERSION)

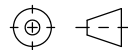
UNLESS OTHERWISE SPECIFIED, DIMENSIONS ARE IN INCHES [mm]	APPROVALS	DATE	 50 High Street, West Mill, North Andover, MA 01845 USA. Phone: 1.800.341.5266 1.978.682.6936
	OVERALL CABLE LENGTH TOLERANCE: ≤12 [305] = +1 [25] / -0 >12 [305] ≤60 [1524] = +2 [51] / -0 >60 [1524] ≤120 [3048] = +4 [102] / -0 >120 [3048] ≤300 [7620] = +6 [152] / -0 >300 [7620] = +5% / -0	DRAWN BY DFRISIELLO	
ALL OTHER DIMENSIONAL TOLERANCES: .X = ± .2 [5] FRACTIONS ± 1/32 .XX = ± .02 [.5] ANGLES ± 1° .XXX = ± .005 [.13]	CHECKED BY DZINN	05/18/2022	CATEGORY FIBER OPTIC
	APPROVED BY PHOSPODAR	05/18/2022	
THIRD-ANGLE PROJECTION	CONFIGURATION DETAILS OF UNDIMENSIONED FEATURES MAY VARY	COLOR VARIATIONS MAY OCCUR	SIZE A CAGE CODE 43321 ITEM NO. FOB-2F3DM2R-M REV. A
	SCALE: NONE CAD FILE: FOB-2F3DM2R-M.SLDDRW		SHEET 1 OF 1