

THE INFORMATION CONTAINED IN THIS DRAWING IS THE SOLE PROPERTY OF L-COM, INC. ANY REPRODUCTION IN PART OR WHOLE WITHOUT THE WRITTEN PERMISSION OF L-COM, INC. IS PROHIBITED.

| REVISIONS | | | |
|-----------|-----------------|------------|-----------|
| REV | DESCRIPTION | DATE | APPROVED |
| A | INITIAL RELEASE | 08/07/2020 | PHOSPODAR |
| | | | |
| | | | |

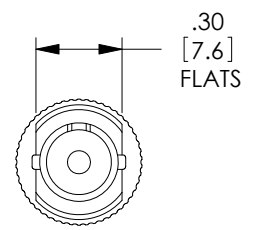
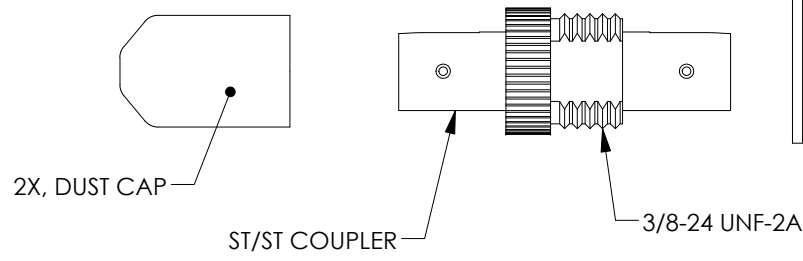
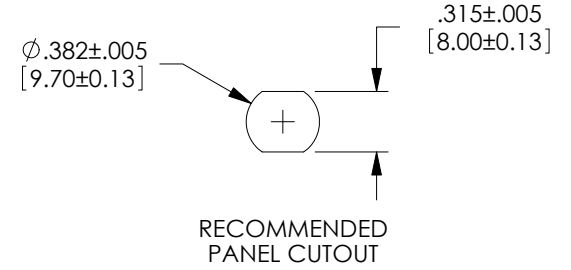
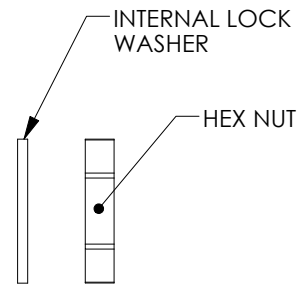
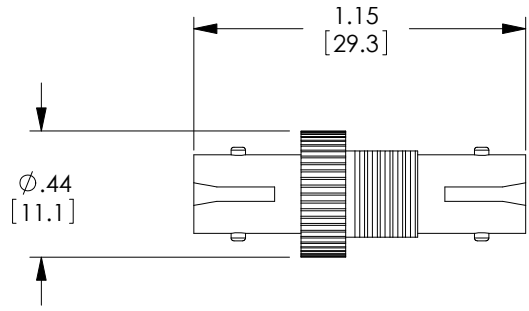

NOTES:

MATERIAL:
 SLEEVE: PHOSPHOR BRONZE
 BODY: BRASS, NICKEL PLATED
 DUST CAP: VINYL, RED

RECOMMENDED PANEL THICKNESS: .06" [1.5]

ALL DIMENSIONS ARE FOR REFERENCE ONLY.

COMPONENT SHALL BE INDIVIDUALLY PACKAGED IN ACCORDANCE WITH L-COM SPECIFICATION PS-0031.

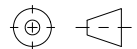
| | | | | |
|--|---|--|--|---|
| UNLESS OTHERWISE SPECIFIED, DIMENSIONS ARE IN INCHES [mm] OVERALL CABLE LENGTH TOLERANCE: ≤12 [305] = +1 [25] / -0 >12 [305] ≤60 [1524] = +2 [51] / -0 >60 [1524] ≤120 [3048] = +4 [102] / -0 >120 [3048] ≤300 [7620] = +6 [152] / -0 >300 [7620] = +5% / -0 ALL OTHER DIMENSIONAL TOLERANCES: .X = ± .2 [5] FRACTIONS ± 1/32 .XX = ± .02 [.5] ANGLES ± 1° .XXX = ± .005 [.13] | APPROVALS DRAWN BY DFRISIELLO CHECKED BY PHOSPODAR APPROVED BY PHOSPODAR | DATE 06/29/2020 08/07/2020 08/07/2020 |  an INFINITO brand | 50 High Street, West Mill, North Andover, MA 01845 USA. Phone: 1.800.341.5266 1.978.682.6936 |
| | CONFIGURATION DETAILS OF UNDIMENSIONED FEATURES MAY VARY | | CATEGORY FIBER OPTICS | |
| THIRD-ANGLE PROJECTION  | COLOR VARIATIONS MAY OCCUR | | PRODUCT DESCRIPTION ST Simplex Multimode Coupler, Metal Body | |
| SIZE A | | CAGE CODE 43321 | ITEM NO. FOA-951 | REV. A |
| SCALE: NONE | | CAD FILE: FOA-951.SLDDRW | | SHEET 1 OF 1 |