

THE INFORMATION CONTAINED IN THIS DRAWING IS THE SOLE PROPERTY OF L-COM, INC. ANY REPRODUCTION IN PART OR WHOLE WITHOUT THE WRITTEN PERMISSION OF L-COM, INC. IS PROHIBITED.

REVISIONS			
REV	DESCRIPTION	DATE	APPROVED
A	INITIAL RELEASE	08/07/2020	PHOSPODAR

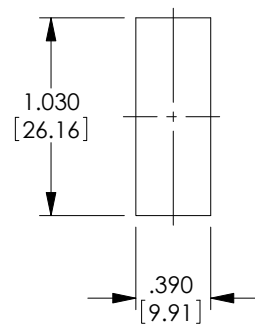
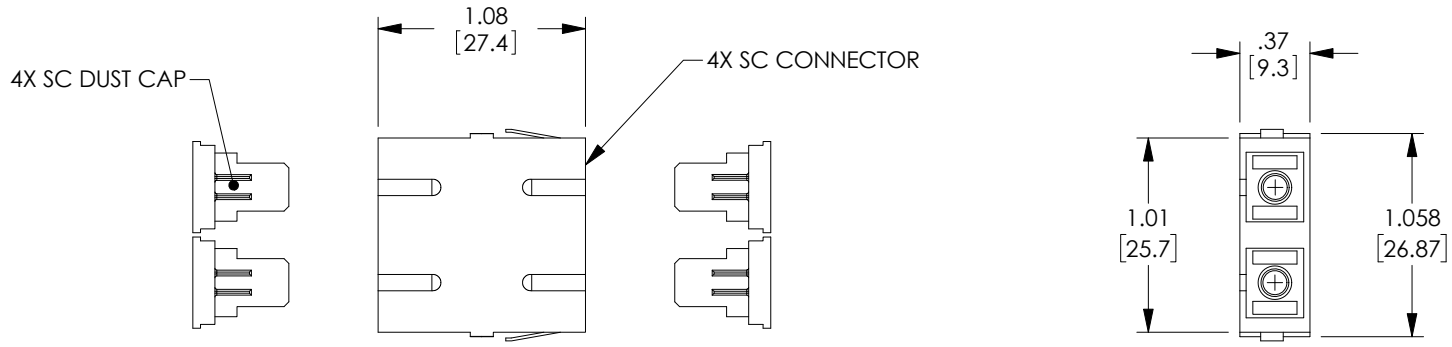

RECOMMENDED PANEL CUTOUT

**NOTES:**

**MATERIALS:**  
 SLEEVE: ZIRCONIA  
 BODY: ABS THERMOPLASTIC, BLUE  
 DUST CAP: ENGINEERING PLASTIC, BLACK  
 MOUNTING CLIPS: STAINLESS STEEL

RECOMMENDED PANEL THICKNESS: .06" [1.5]

ALL DIMENSIONS ARE FOR REFERENCE ONLY.

COMPONENT SHALL BE INDIVIDUALLY PACKAGED IN ACCORDANCE WITH L-COM SPECIFICATION PS-0031.

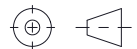
UNLESS OTHERWISE SPECIFIED, DIMENSIONS ARE IN INCHES [mm] OVERALL CABLE LENGTH TOLERANCE: ≤12 [305] = +1 [25] / -0 >12 [305] ≤60 [1524] = +2 [51] / -0 >60 [1524] ≤120 [3048] = +4 [102] / -0 >120 [3048] ≤300 [7620] = +6 [152] / -0 >300 [7620] = +5% / -0 ALL OTHER DIMENSIONAL TOLERANCES: .X = ± .2 [5]   FRACTIONS ± 1/32 .XX = ± .02 [.5]   ANGLES ± 1° .XXX = ± .005 [.13]	APPROVALS	DATE	 50 High Street, West Mill, North Andover, MA 01845 USA. Phone: 1.800.341.5266 1.978.682.6936
	DRAWN BY DFRISIELLO	06/15/2020	
APPROVED BY PHOSPODAR	08/07/2020	CATEGORY <b>FIBER OPTICS</b>	
THIRD-ANGLE PROJECTION 	CONFIGURATION DETAILS OF UNDIMENSIONED FEATURES MAY VARY	PRODUCT DESCRIPTION <b>SC Duplex Single Mode Coupler, No Flange, Blue</b>	
COLOR VARIATIONS MAY OCCUR	SIZE <b>A</b>	CAGE CODE <b>43321</b>	ITEM NO. <b>FOA-910</b>
SCALE: NONE		CAD FILE: FOA-910.SLDDRW	
SHEET 1 OF 1			REV. <b>A</b>