

THE INFORMATION CONTAINED IN THIS DRAWING IS THE SOLE PROPERTY OF L-COM, INC. ANY REPRODUCTION IN PART OR WHOLE WITHOUT THE WRITTEN PERMISSION OF L-COM, INC. IS PROHIBITED.

| REVISION |     |                 |            |            |           |
|----------|-----|-----------------|------------|------------|-----------|
| ZONE     | REV | DESCRIPTION     | DATE       | CHANGED BY | APPROVED  |
|          | A   | INITIAL RELEASE | 09/25/2023 | LNAGARAJ   | PHOSPODAR |

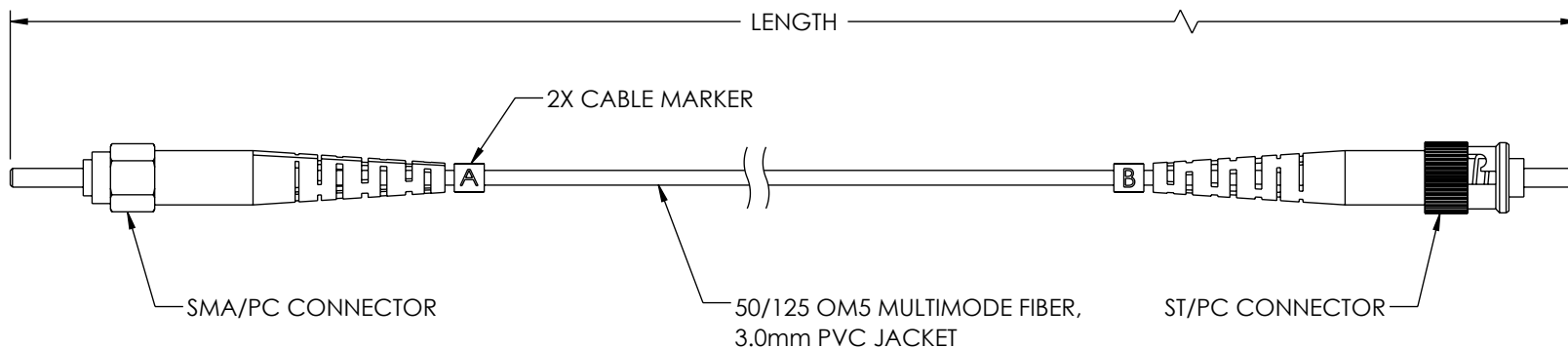

**SPECIFICATIONS:**

|                                   |                         |
|-----------------------------------|-------------------------|
| FIBER TYPE/MODE                   | OM5 50/125um            |
| OPERATING WAVELENGTH              | 850nm, 1300nm           |
| INSERTION LOSS                    | ≤0.2dB                  |
| RETURN LOSS                       | ≥30dB                   |
| MINIMUM BEND RADIUS (FIBER CORE)  | 10mm                    |
| MINIMUM BEND RADIUS (FIBER CABLE) | 10/5D (DYNAMIC/STATIC)  |
| OPERATING TEMPERATURE             | -40°C~+60°C             |
| STORAGE TEMPERATURE               | -45°C~+85°C             |
| COMPLIANT STANDARDS               | CE, RoHS, REACH and IEC |

| PART NUMBER         | LENGTH<br>METER [FEET] |
|---------------------|------------------------|
| FCA-SMPSTP-SPM5V-01 | 1.0 [3.28]             |
| FCA-SMPSTP-SPM5V-05 | 5.0 [16.40]            |

**NOTES:**

- ALL CONNECTORS ACCOMPANIED WITH A DUST CAP INSTALLED (NOT SHOWN).
- CABLE ASSEMBLY SHALL BE INDIVIDUALLY PACKAGED.

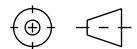
|   |                            |             |   |   |
|---|----------------------------|-------------|---|---|
| UNLESS OTHERWISE SPECIFIED, DIMENSIONS ARE IN INCHES [mm]<br>OVERALL CABLE LENGTH TOLERANCE:<br>≤12 [305] = +1 [25] / -0<br>>12 [305] ≤60 [1524] = +2 [51] / -0<br>>60 [1524] ≤120 [3048] = +4 [102] / -0<br>>120 [3048] ≤300 [7620] = +6 [152] / -0<br>>300 [7620] = +5% / -0<br>ALL OTHER DIMENSIONAL TOLERANCES:<br>.X = ± .2 [5]   FRACTIONS ± 1/32<br>.XX = ± .02 [5]   ANGLES ± 1°<br>.XXX = ± .005 [1.3] | APPROVALS                  | DATE        | <br>an INFINITI® brand | 50 High Street, West Mill,<br>North Andover, MA 01845 USA.<br>Phone: 1.800.341.5266<br>1.978.682.6936 |
|   | DRAWN BY<br>LNAGARAJ       | 09/25/2023  |   |   |
| THIRD-ANGLE PROJECTION<br>   | CHECKED BY<br>TCAHALANE    | 09/28/2023  | CATEGORY<br>FIBER OPTICS  |   |
|   | APPROVED BY<br>PHOSPODAR   | 09/29/2023  | PRODUCT DESCRIPTION<br>FIBER OPTIC PATCH CABLE SMA TO ST SIMPLEX 50/125 MULTIMODE PVC                       |   |
| CONFIGURATION DETAILS OF UNDIMENSIONED FEATURES MAY VARY  | COLOR VARIATIONS MAY OCCUR | SIZE<br>A   | CAGE CODE<br>43321  | ITEM NO.<br>FCA-SMPSTP-SPM5V  |
|   |                            | SCALE: NONE | CAD FILE: FCA-SMPSTP-SPM5V.SLDDRW   | REV.<br>A   |
|   |                            |             | SHEET 1 OF 1  |   |