

6

5

4

3

2

1

REVISION					
ZONE	REV	DESCRIPTION	DATE	CHANGED BY	APPROVED
	B	UPDATED PER ECO-13411	02/07/2024	HBAKKE	DREBECK

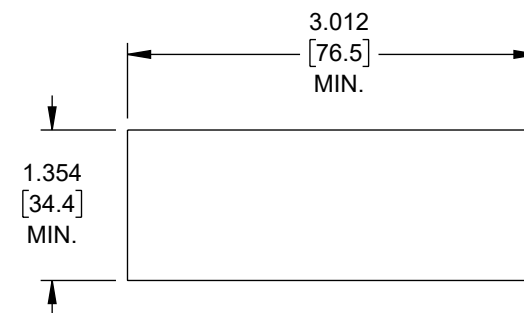
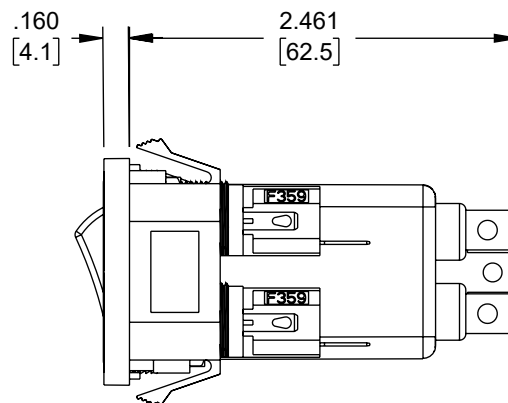
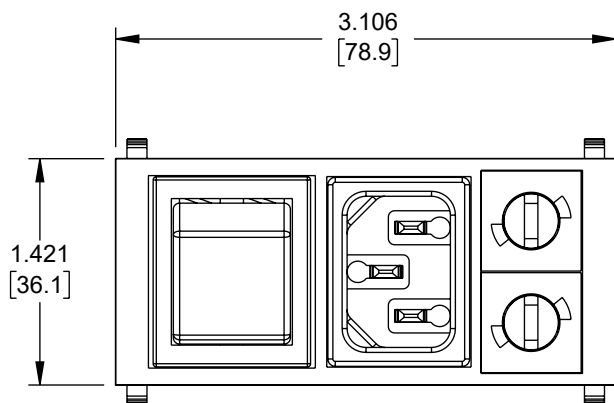

PANEL FIXING DETAILS

## NOTES:-

- CONNECTOR TYPE: C14
- RATING: 6A, 250VAC
- FEATURES:  
SNAPS INTO 1.0-3.0mm PANEL 6.3mm QUICK-CONNECT TERMINATIONS  
EMI FILTERED DOUBLE CONTACT ON/OFF SWITCH DOUBLE FUSEHOLDER
- PACKAGING NOTE:  
CONNECTOR SHALL BE INDIVIDUALLY PACKAGED, LABEL PER LSP-010-5.
- ALL DIMENSIONS FOR REFERENCE ONLY

THE INFORMATION CONTAINED IN THIS DRAWING IS THE SOLE PROPERTY OF INFINITE ELECTRONICS, INC. ANY REPRODUCTION IN PART OR WHOLE WITHOUT THE WRITTEN PERMISSION OF INFINITE ELECTRONICS, INC. IS PROHIBITED. THESE COMMODITIES, TECHNOLOGY OR SOFTWARE WERE EXPORTED FROM THE UNITED STATES IN ACCORDANCE WITH THE EXPORT ADMINISTRATION REGULATIONS. DIVERSION CONTRARY TO U.S. LAW PROHIBITED.

UNLESS OTHERWISE SPECIFIED  
LEADING DIMENSIONS ARE INCHES  
DIMENSIONS IN [ ] ARE MILLIMETERS

TOLERANCES:  
X = ±.2 [5]      FRACTIONS  
.XX = ±.02 [0.5]      ± 1/32  
.XXX = ±.005 [0.13]      ANGLES ± 1°

CABLE LENGTH TOLERANCES:  
≤12 [305] = +1 [25] / -0  
>12 [305] ≤ 60 [1524] = +2 [51] / -0  
>60 [1524] ≤ 120 [3048] = +4 [102] / -0  
>120 [3048] ≤ 300 [7620] = +6 [152] / -0  
>300 [7620] = +5% / -0

ALL DIMENSIONS ARE FOR REFERENCE ONLY  
AND SUBJECT TO CHANGE WITHOUT NOTICE.  
UN-DIMENSIONED/NON-CRITICAL FEATURES  
MAY VARY IN SIZE AND LOCATION  
COLORS MAY VARY

**L-com**  
an INFINIT@ brand

Website: [www.L-com.com](http://www.L-com.com)  
Phone: 1.800.341.5266 | 1.978.682.6936

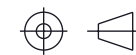

INTERPRET ALL DIMENSIONS AND  
TOLERANCES PER ASME Y14.5

SCALE	SHEET
NONE	1 OF 1

DESCRIPTION  
AC PEM C14 1.0mm TO 3.0mm PANEL SNAP-IN 6.3mm QUICK-  
CONNECT EMI FILTERED DOUBLE CONTACT SWITCH 2X  
FUSEHOLDERS

SIZE	CAGE CODE	DRAWN BY	ITEM NO.	REV
A	43321	PSRINIVAS	ACM-C4-NXQ6ER2F2-LC	B

6

5

4

3

2

1