

6

5

4

3

2

1

## REVISION

ZONE	REV	DESCRIPTION	DATE	CHANGED BY	APPROVED
	B	UPDATED PER ECO-13411	02/07/2024	HBAKKE	DREBECK

F

F

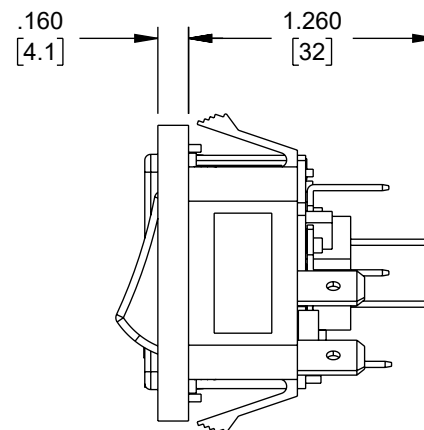
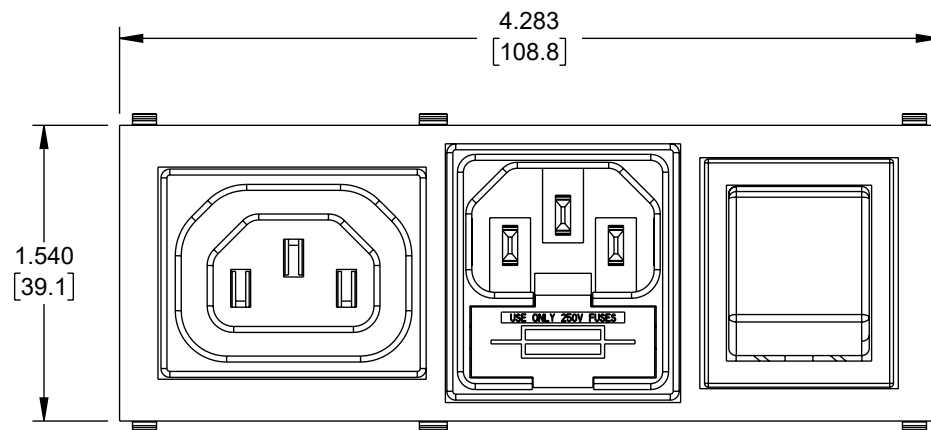

E

E

D

D



C

C

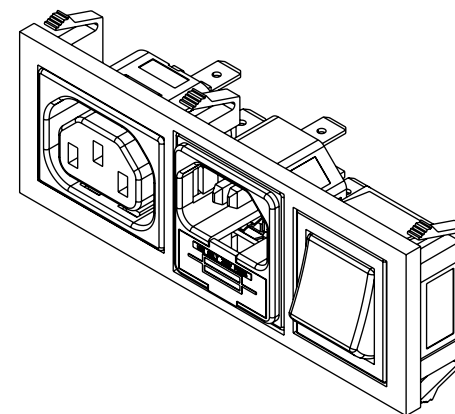

B

B

## NOTES:-

- CONNECTOR TYPE: 60320-2-2/F
- RATING: 10A, 250VAC
- FEATURES: SNAPS INTO 1.0-3.0mm PANEL 6.3mm QUICK-CONNECT TERMINATIONS ON/OFF SWITCH SINGLE FUSEHOLDER
- PACKAGING NOTE:  
CONNECTOR SHALL BE INDIVIDUALLY PACKAGED, LABEL PER LSP-010-5.
- ALL DIMENSIONS FOR REFERENCE ONLY

A

A

THE INFORMATION CONTAINED IN THIS DRAWING IS THE SOLE PROPERTY OF INFINITE ELECTRONICS, INC. ANY REPRODUCTION IN PART OR WHOLE WITHOUT THE WRITTEN PERMISSION OF INFINITE ELECTRONICS, INC. IS PROHIBITED. THESE COMMODITIES, TECHNOLOGY OR SOFTWARE WERE EXPORTED FROM THE UNITED STATES IN ACCORDANCE WITH THE EXPORT ADMINISTRATION REGULATIONS. DIVERSION CONTRARY TO U.S. LAW PROHIBITED.

UNLESS OTHERWISE SPECIFIED  
LEADING DIMENSIONS ARE INCHES  
DIMENSIONS IN [ ] ARE MILLIMETERS

TOLERANCES:  
 X = ±.2 [5]      FRACTIONS ± 1/32  
 .XX = ±.02 [0.5]      ANGLES ± 1°  
 .XXX = ±.005 [0.13]

CABLE LENGTH TOLERANCES:  
 ≤12 [305] = +1 [25] / -0  
 >12 [305] ≤ 60 [1524] = +2 [51] / -0  
 >60 [1524] ≤ 120 [3048] = +4 [102] / -0  
 >120 [3048] ≤ 300 [7620] = +6 [152] / -0  
 >300 [7620] = +5% / -0

ALL DIMENSIONS ARE FOR REFERENCE ONLY  
AND SUBJECT TO CHANGE WITHOUT NOTICE.  
UN-DIMENSIONED/NON-CRITICAL FEATURES  
MAY VARY IN SIZE AND LOCATION  
COLORS MAY VARY

**L-com**  
an INFINIT® brand

Website: [www.L-com.com](http://www.L-com.com)  
Phone: 1.800.341.5266 | 1.978.682.6936

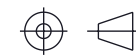

INTERPRET ALL DIMENSIONS AND  
TOLERANCES PER ASME Y14.5

SCALE	SHEET
NONE	1 OF 1

## DESCRIPTION

AC PEM 320-2-2/F, C14, 1.0mm TO 3.0mm PANEL SNAP-IN 6.3mm  
QUICK-CONNECT ON/OFF SWITCH SINGLE FUSEHOLDER

SIZE	CAGE CODE	DRAWN BY	ITEM NO.	REV
A	43321	PSRINIVAS	ACM-2FC4-NXQ6R1LF-LC	B

6

5

4

3

2

1