

THE INFORMATION CONTAINED IN THIS DRAWING IS THE SOLE PROPERTY OF L-COM, INC. ANY REPRODUCTION IN PART OR WHOLE WITHOUT THE WRITTEN PERMISSION OF L-COM, INC. IS PROHIBITED.

REVISION					
ZONE	REV	DESCRIPTION	DATE	CHANGED BY	APPROVED
	A	INITIAL RELEASE	09/22/2023	PSRINIVAS	DREBECK

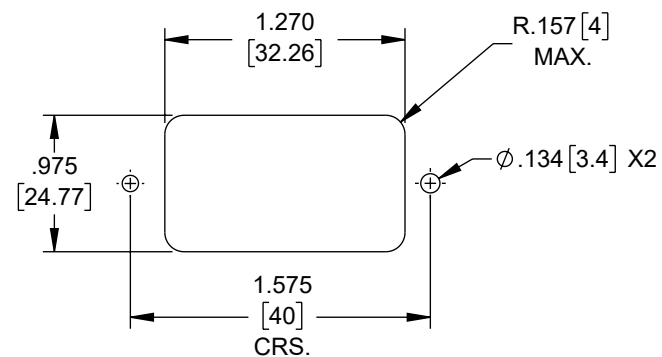

FIXING DETAILS

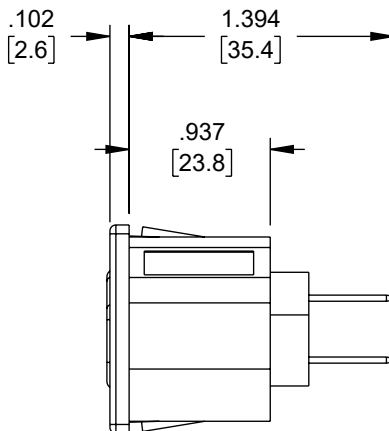
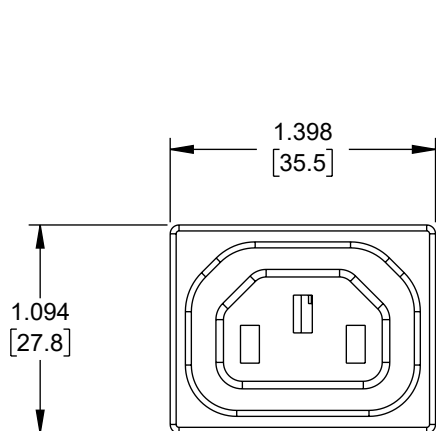
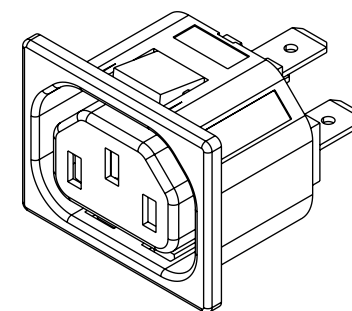

NOTES:-

- CONNECTOR TYPE: 60320-2-2/F
- RATING: 10A, 250VAC
- FEATURES:
SNAPS INTO 1.5mm PANEL 6.3mm QUICK-CONNECT SHUTTERED
- PACKAGING NOTE:
CONNECTOR SHALL BE INDIVIDUALLY PACKAGED, LABEL PER ILS-100
- ALL DIMENSIONS FOR REFERENCE ONLY

<p>UNLESS OTHERWISE SPECIFIED, DIMENSIONS ARE IN INCHES [mm]</p> <p>OVERALL CABLE LENGTH TOLERANCE: ≤ 12 [305] = +1 [25] / -0 > 12 [305] ≤ 60 [1524] = +2 [51] / -0 > 60 [1524] ≤ 120 [3048] = +4 [102] / -0 > 120 [3048] ≤ 300 [7620] = +6 [152] / -0 > 300 [7620] = +5% / -0</p> <p>ALL OTHER DIMENSIONAL TOLERANCES: .X = ± .2 [5] FRACTIONS ± 1/32 .XX = ± .02 [5] ANGLES ± 1° .XXX = ± .005 [1.3]</p> <p>THIRD-ANGLE PROJECTION</p>	APPROVALS	DATE	<p>50 High Street, West Mill, North Andover, MA 01845 USA. Phone: 1.800.341.5266 1.978.682.6936</p>	
	DRAWN BY PSRINIVAS	09/22/2023		
	CHECKED BY DFRISIELLO	09/22/2023		
	APPROVED BY DREBECK	09/22/2023		
	<p>CONFIGURATION DETAILS OF UNDIMENSIONED FEATURES MAY VARY</p>		<p>CATEGORY</p> <p>IEC CONNECTORS_PANEL SNAP-IN</p>	
	<p>COLOR VARIATIONS MAY OCCUR</p>		<p>PRODUCT DESCRIPTION</p> <p>AC PEM 320-2-2/F 1.5mm PANEL SNAP-IN 6.3mm QUICK-CONNECT SHUTTERED</p>	
	SIZE A	CAGE CODE 43321	ITEM NO. ACM-2F-N15Q6U-LC	REV. A
	SCALE: NONE	CAD FILE: ACM-2F-N15Q6U-LC.SLDDRW	SHEET 1 OF 1	