

6

5

4

3

2

1

## REVISION

ZONE	REV	DESCRIPTION	DATE	CHANGED BY	APPROVED
	B	ECO-13362	01/10/2024	BPUCHASKI	DREBECK

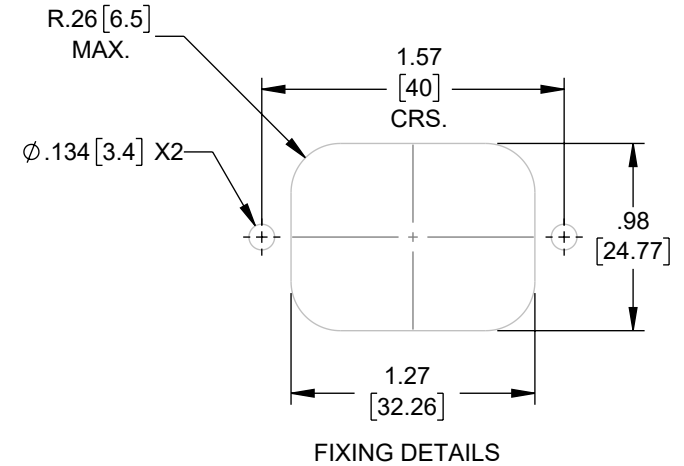
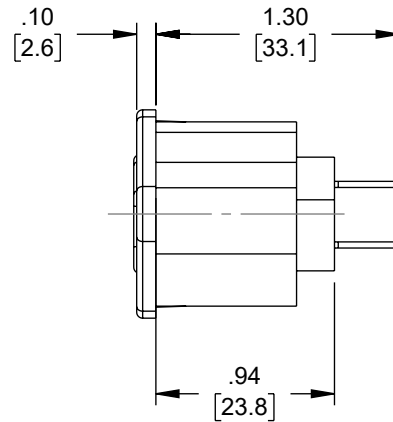
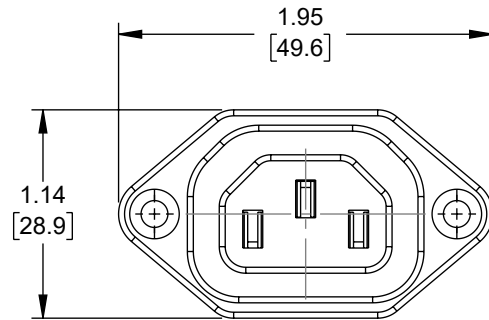

## NOTES:-

- CONNECTOR TYPE: 60320-2-2/F
- RATING: 15A, 250V AC
- FEATURES: FLANGE MOUNT 2.8mm SOLDER TAB TERMINATIONS SHUTTERED
- PACKAGING NOTE:  
ITEM SHALL BE INDIVIDUALLY PACKAGED, LABEL PER LSP-010-5
- ALL DIMENSIONS FOR REFERENCE ONLY

THE INFORMATION CONTAINED IN THIS DRAWING IS THE SOLE PROPERTY OF INFINITE ELECTRONICS, INC. ANY REPRODUCTION IN PART OR WHOLE WITHOUT THE WRITTEN PERMISSION OF INFINITE ELECTRONICS, INC. IS PROHIBITED. THESE COMMODITIES, TECHNOLOGY OR SOFTWARE WERE EXPORTED FROM THE UNITED STATES IN ACCORDANCE WITH THE EXPORT ADMINISTRATION REGULATIONS. DIVERSION CONTRARY TO U.S. LAW PROHIBITED.

UNLESS OTHERWISE SPECIFIED  
LEADING DIMENSIONS ARE INCHES  
DIMENSIONS IN [ ] ARE MILLIMETERS

TOLERANCES:  
 .X =  $\pm 2$  [5]      FRACTIONS  
 .XX =  $\pm 0.02$  [0.5]       $\pm 1/32$   
 .XXX =  $\pm 0.005$  [0.13]      ANGLES  $\pm 1^\circ$

CABLE LENGTH TOLERANCES:  
 $\leq 12$  [305] =  $+1$  [25] / -0  
 $>12$  [305]  $\leq 60$  [1524] =  $+2$  [51] / -0  
 $>60$  [1524]  $\leq 120$  [3048] =  $+4$  [102] / -0  
 $>120$  [3048]  $\leq 300$  [7620] =  $+6$  [152] / -0  
 $>300$  [7620] =  $+5\%$  / -0

ALL DIMENSIONS ARE FOR REFERENCE ONLY  
AND SUBJECT TO CHANGE WITHOUT NOTICE.  
UN-DIMENSIONED/NON-CRITICAL FEATURES  
MAY VARY IN SIZE AND LOCATION  
COLORS MAY VARY

**L-com**  
an INFINIT@ brand

Website: [www.L-com.com](http://www.L-com.com)  
Phone: 1.800.341.5266 | 1.978.682.6936

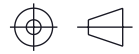

INTERPRET ALL DIMENSIONS AND  
TOLERANCES PER ASME Y14.5

SCALE	SHEET
NONE	1 OF 1

DESCRIPTION  
AC PEM 320-2-2/F PANEL FLANGE 2.8mm SOLDER TERMINALS SHUTTERED

SIZE	CAGE CODE	DRAWN BY	ITEM NO.	REV
A	43321	PSRINIVAS	ACM-2F-GSU-LC	B

6

5

4

3

2

1