

6

5

4

3

2

1

REVISION					
ZONE	REV	DESCRIPTION	DATE	CHANGED BY	APPROVED
	B	UPDATED PER ECO-13411	02/07/2024	HBAKKE	DREBECK

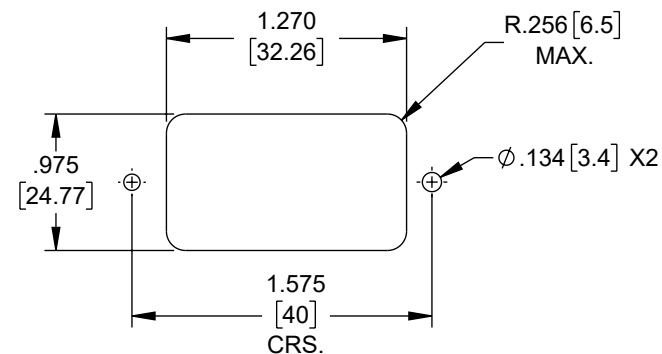
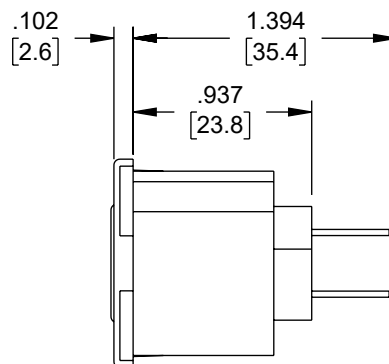
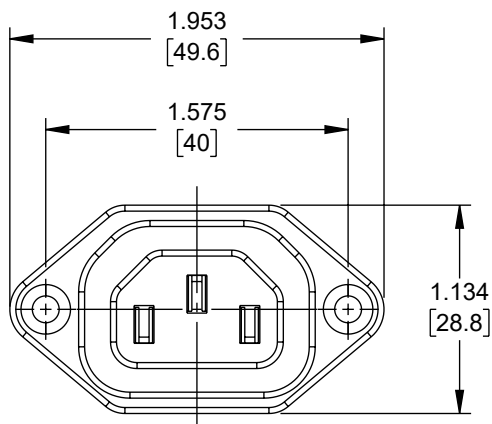

FIXING DETAILS

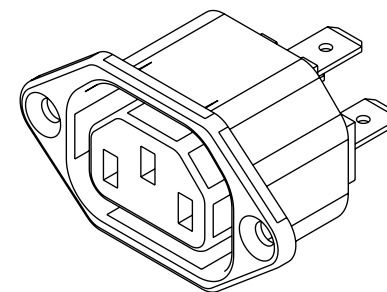

NOTES:-

- CONNECTOR TYPE: 60320-2-2/F
- RATING: 15A, 250VAC
- FEATURES: SNAP IN PANEL MOUNT 6.3mm QUICK-CONNECT TERMINATIONS
- PACKAGING NOTE:
CONNECTOR SHALL BE INDIVIDUALLY PACKAGED, LABEL PER LSP-010-5.
- ALL DIMENSIONS FOR REFERENCE ONLY

THE INFORMATION CONTAINED IN THIS DRAWING IS THE SOLE PROPERTY OF INFINITE ELECTRONICS, INC. ANY REPRODUCTION IN PART OR WHOLE WITHOUT THE WRITTEN PERMISSION OF INFINITE ELECTRONICS, INC. IS PROHIBITED. THESE COMMODITIES, TECHNOLOGY OR SOFTWARE WERE EXPORTED FROM THE UNITED STATES IN ACCORDANCE WITH THE EXPORT ADMINISTRATION REGULATIONS. DIVERSION CONTRARY TO U.S. LAW PROHIBITED.

UNLESS OTHERWISE SPECIFIED
LEADING DIMENSIONS ARE INCHES
DIMENSIONS IN [] ARE MILLIMETERS

TOLERANCES:
X = ±.2 [5] FRACTIONS
XX = ±.02 [0.5] ± 1/32
.XXX = ±.005 [0.13] ANGLES ± 1°

CABLE LENGTH TOLERANCES:
≤12 [305] = +1 [25] / -0
>12 [305] ≤ 60 [1524] = +2 [51] / -0
>60 [1524] ≤ 120 [3048] = +4 [102] / -0
>120 [3048] ≤ 300 [7620] = +6 [152] / -0
>300 [7620] = +5% / -0

ALL DIMENSIONS ARE FOR REFERENCE ONLY
AND SUBJECT TO CHANGE WITHOUT NOTICE.
UN-DIMENSIONED/NON-CRITICAL FEATURES
MAY VARY IN SIZE AND LOCATION
COLORS MAY VARY

L-com
an INFINIT® brand

Website: www.L-com.com
Phone: 1.800.341.5266 | 1.978.682.6936



INTERPRET ALL DIMENSIONS AND
TOLERANCES PER ASME Y14.5

SCALE	SHEET
NONE	1 OF 1

DESCRIPTION
AC PEM 320-2-2/F PANEL FLANGE 6.3mm QUICK-CONNECT

SIZE	CAGE CODE	DRAWN BY	ITEM NO.	REV
A	43321	PSRINIVAS	ACM-2F-GQ6-LC	B

6

5

4

3

2

1