

THE INFORMATION CONTAINED IN THIS DRAWING IS THE SOLE PROPERTY OF SHOW ME CABLES, INC. ANY REPRODUCTION IN PART OR WHOLE WITHOUT THE WRITTEN PERMISSION OF SHOW ME CABLES, INC. IS PROHIBITED.

REVISIONS			
REV	DESCRIPTION	DATE	APPROVED
1	INITIAL RELEASE	04/08/2021	DGUTTADAUR

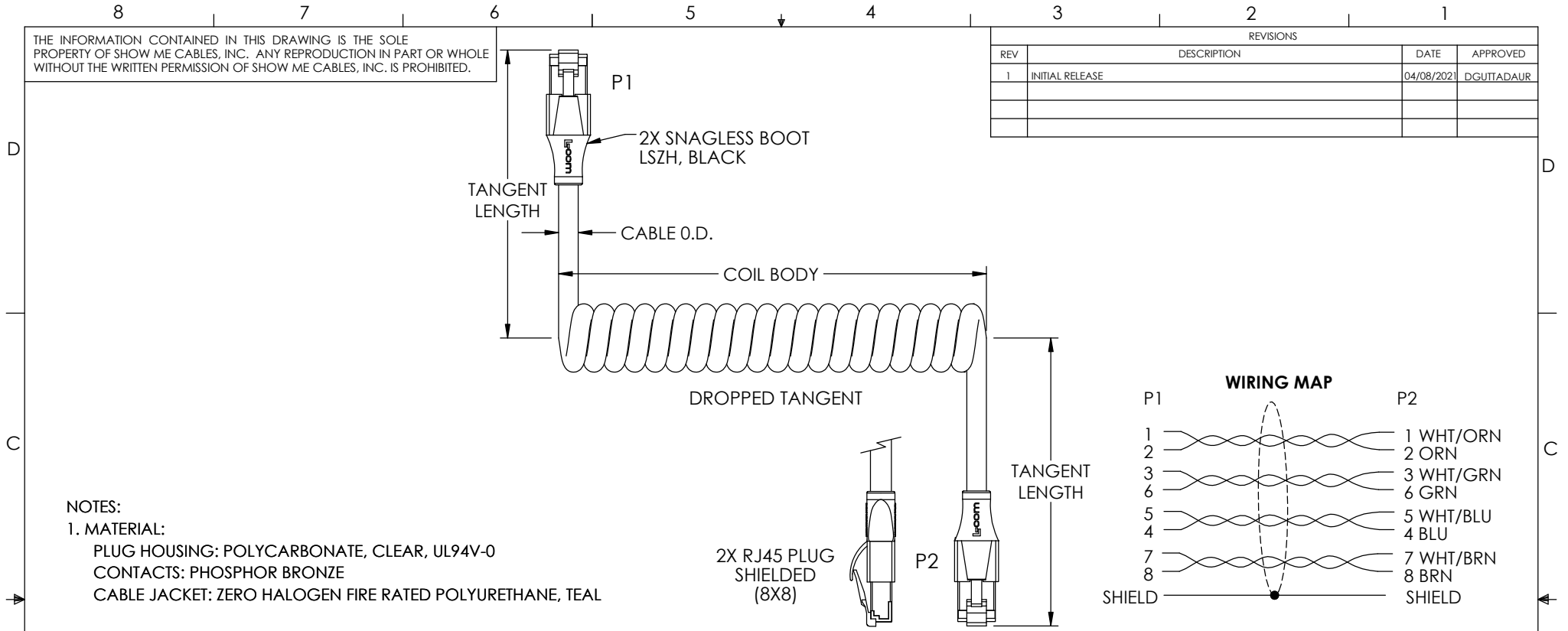

NOTES:

1. MATERIAL:

PLUG HOUSING: POLYCARBONATE, CLEAR, UL94V-0
 CONTACTS: PHOSPHOR BRONZE
 CABLE JACKET: ZERO HALOGEN FIRE RATED POLYURETHANE, TEAL

2. FINISH:

CONTACTS: 50 μINCHES GOLD IN CONTACT AREA OVER
 100 μINCHES NICKEL PLATE OVERALL

3. CABLE CHARACTERISTICS:

CAT5e COIL CORD F/UTP HIGH FLEX ZERO HALOGEN POLYURETHANE
 6X EXPANSION LENGTH DROPPED TANGENT
 SHIELDED (4) TWISTED PAIRS TWISTED TOGETHER
 26AWG STRANDED TINNED COPPER CONDUCTORS
 JACKET: .045" NOM. WALL THICKNESS (PRESSURE) OVERALL DIAMETER .260" NOM.
 OIL RESISTANT (IRM 902 OIL, 7 DAYS @ 100°C)
 JACKET SMOKE GENERATION PER ASTM E662, NOM.
 D_s=251 (FLAMING,@4 MINUTES)
 D_s=16 (NON-FLAMING,@4 MINUTES)
 APPROVED UL AWM STYLE 20352 (60C, 600V)

4. MISCELLANEOUS:

OPERATING TEMPERATURE RANGE: -40°C TO 60°C
 CABLE ASSEMBLY TO BE TESTED FOR CONTINUITY.
 CABLE ASSEMBLY TO BE INDIVIDUALLY PACKAGED.

5. ALL DIMENSIONS ARE FOR REFERENCE ONLY

PART NUMBER	CABLE O.D.	COIL BODY LENGTH	MAX TANGENT LENGTHS	MAX EXPANDED COIL LENGTH
5C90Z-0.5F	.260	0.5 FEET	0.5 FEET	3 FEET
5C90Z-1F	.260	1 FEET	0.5 FEET	6 FEET
5C90Z-2F	.260	2 FEET	0.5 FEET	12 FEET
5C90Z-3F	.260	3 FEET	0.5 FEET	18 FEET
5C90Z-4F	.260	4 FEET	0.5 FEET	24 FEET
5C90Z-5F	.260	5 FEET	0.5 FEET	30 FEET
5C90Z-6F	.260	6 FEET	0.5 FEET	36 FEET
5C90Z-7F	.260	7 FEET	0.5 FEET	42 FEET
5C90Z-8F	.260	8 FEET	0.5 FEET	48 FEET

UNLESS OTHERWISE SPECIFIED, DIMENSIONS ARE IN INCHES [mm] OVERALL CABLE LENGTH TOLERANCE: ≤12 [305] = +1 [25] / -0 >12 [305] ≤60 [1524] = +2 [51] / -0 >60 [1524] ≤120 [3048] = +4 [102] / -0 >120 [3048] ≤300 [7620] = +6 [152] / -0 >300 [7620] = +5% / -0 ALL OTHER DIMENSIONAL TOLERANCES: .X = ± .2 [5] FRACTIONS ± 1/32 .XX = ± .02 [5] ANGLES ± 1° .XXX = ± .005 [13]	APPROVALS DRAWN BY: BPUCHASKI CHECKED BY: DFRISIELLO APPROVED BY: DGUTTADAUR	DATE 04/08/2021 04/08/2021 04/08/2021	115 Chesterfield Industrial Blvd., Chesterfield, MO 63005 Phone: 1.888.519.9505 Fax: 1.888.519.9515
	CONFIGURATION DETAILS OF UNDIMENSIONED FEATURES MAY VARY COLOR VARIATIONS MAY OCCUR	CATEGORY TELECOM MODULAR	
THIRD-ANGLE PROJECTION 	SIZE A	CAGE CODE 3SVT8	ITEM NO. 5C90Z-X
SCALE: NONE		CAD FILE: 5C90Z-X.SLDDRW	REV. A