

## Assembly manual

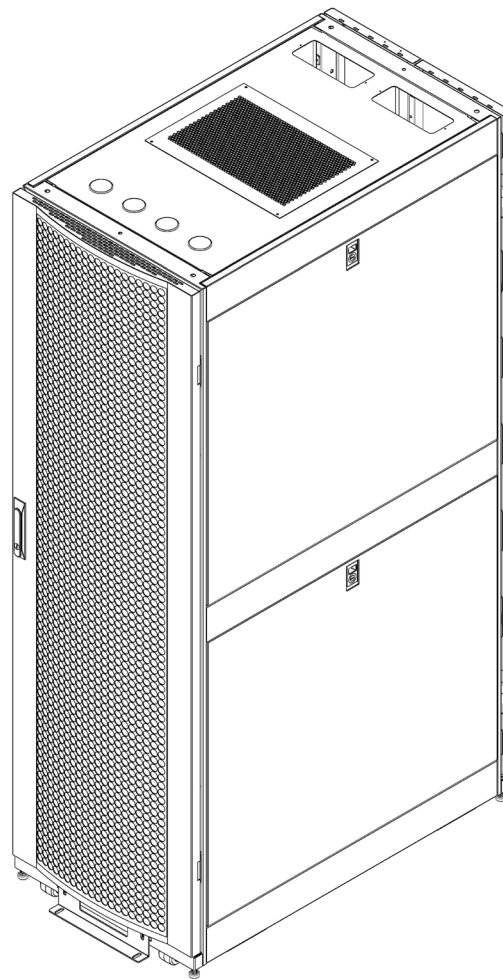

Keep this information for further reference.







Thank you for purchasing an SMC product.

- Please examine the product for any damaged parts. If any part is damaged or missing, contact SMC for assistance. Do not attempt to install or use product if it has been damaged. This product contains small items that could be a choking hazard - keep these items away from children.
- During installation, lay product contents on cardboard or other protective surface to avoid any damage.
- Do not use with equipment that is heavier than the indicated weight capacity for this product. Make sure that the supporting surface will safely support the weight of the equipment and all attached hardware and components. It is recommended that installation be performed by a qualified installer. SMC cannot be held responsible for damage to equipment or personal injury resulting from improper use or installation of product.
- Maintenance: Check that the product is secure and safe to use at regular intervals (at least every three months).
- Limitations of Liability: In no event will SMC, LLC. be liable for any damages, whether direct or indirect, special, punitive, incidental or consequential damages (including, but not limited to, lost profits or revenue, loss of use, lost business opportunities or loss of goodwill) or for the costs of procuring substitute products, arising out of or in connection with the use of the product, whether such liability arises from any claim based upon contract, warranty, tort (including negligence), product liability or otherwise, whether or not seller has been advised of the possibility of such loss or damage. In no event will seller's total cumulative liability, from all causes of action and all theories of liability, exceed the total amounts actually paid to seller by customer under the order that gives rise to any liability hereunder.

# Show Me™

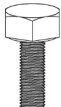
## CABLES

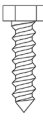
an INFINIT® brand

Sketch Plan	 a: M5	 b: M6	 c: M8	 d: M8	 e: M8	 f: M8
Quantity	56X	24X	4X	4X	4X	4X

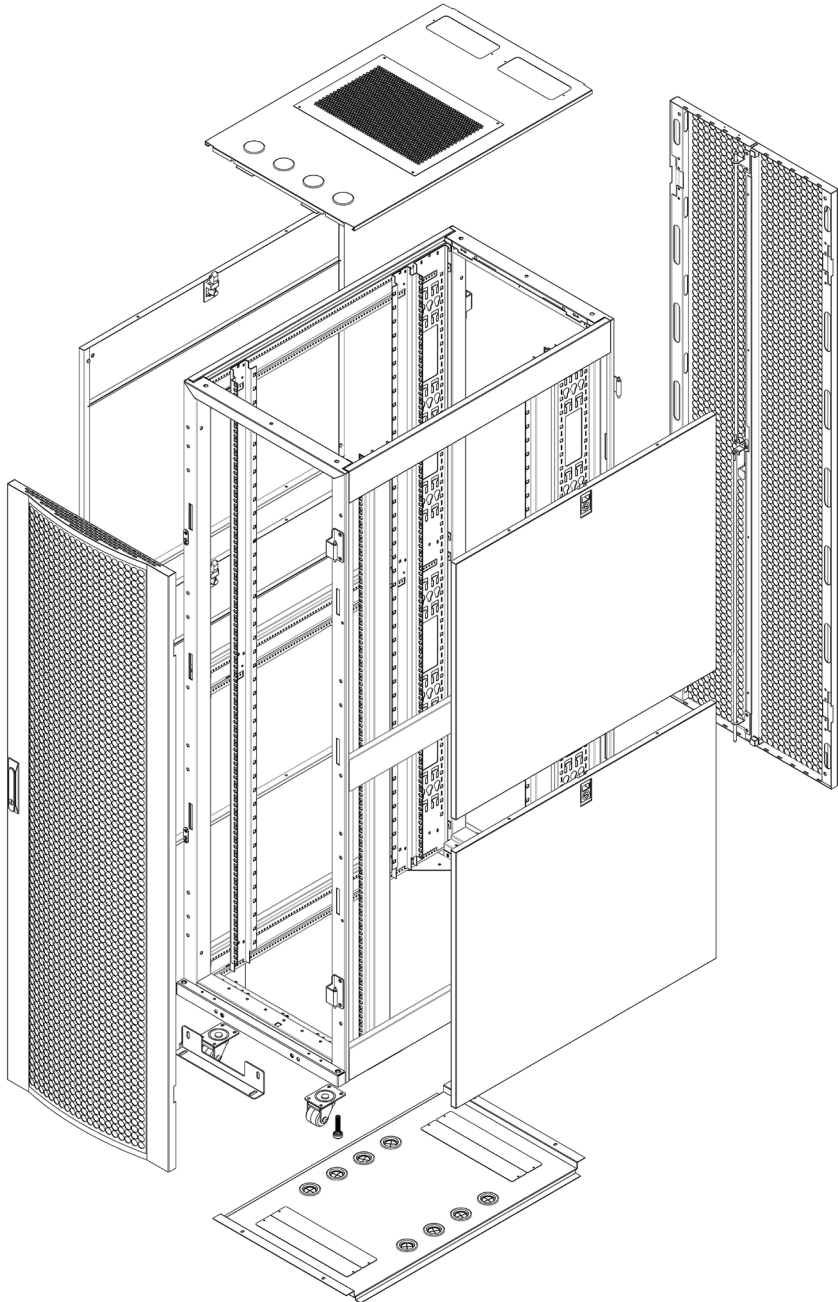

# Show Me™

CABLES

an INFINIT® brand

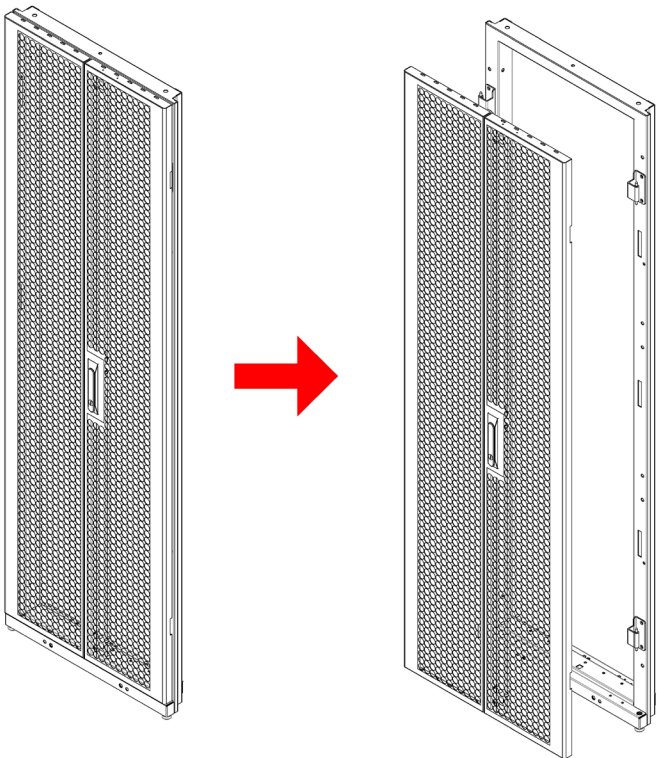
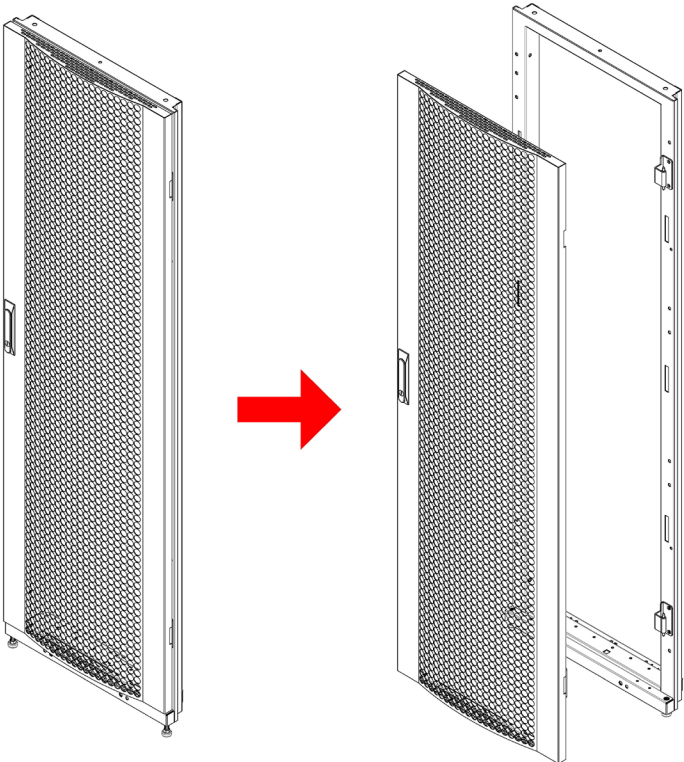

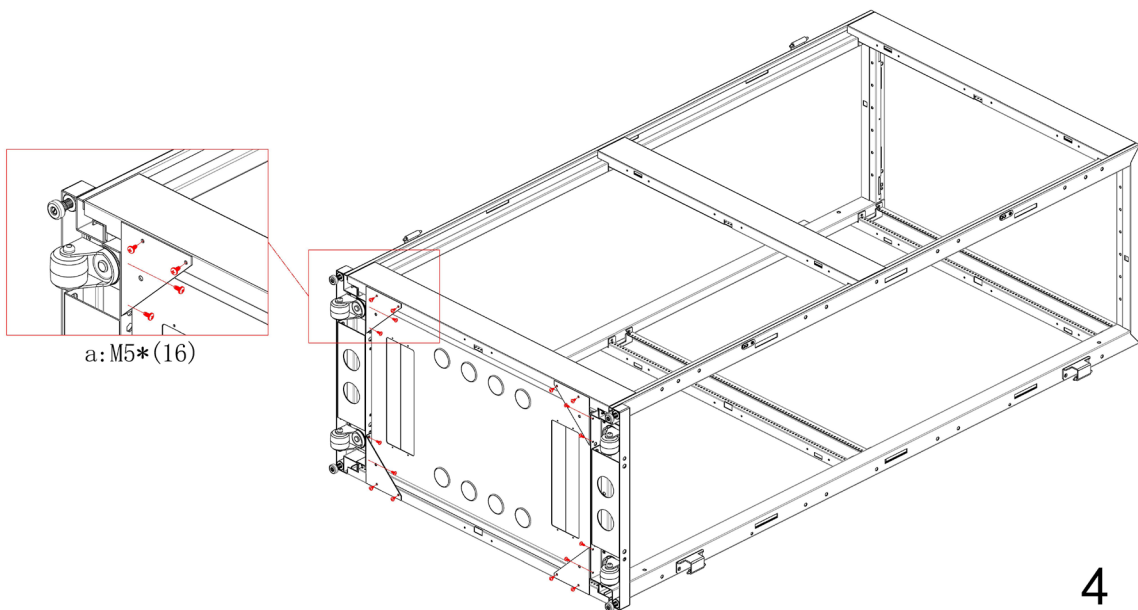
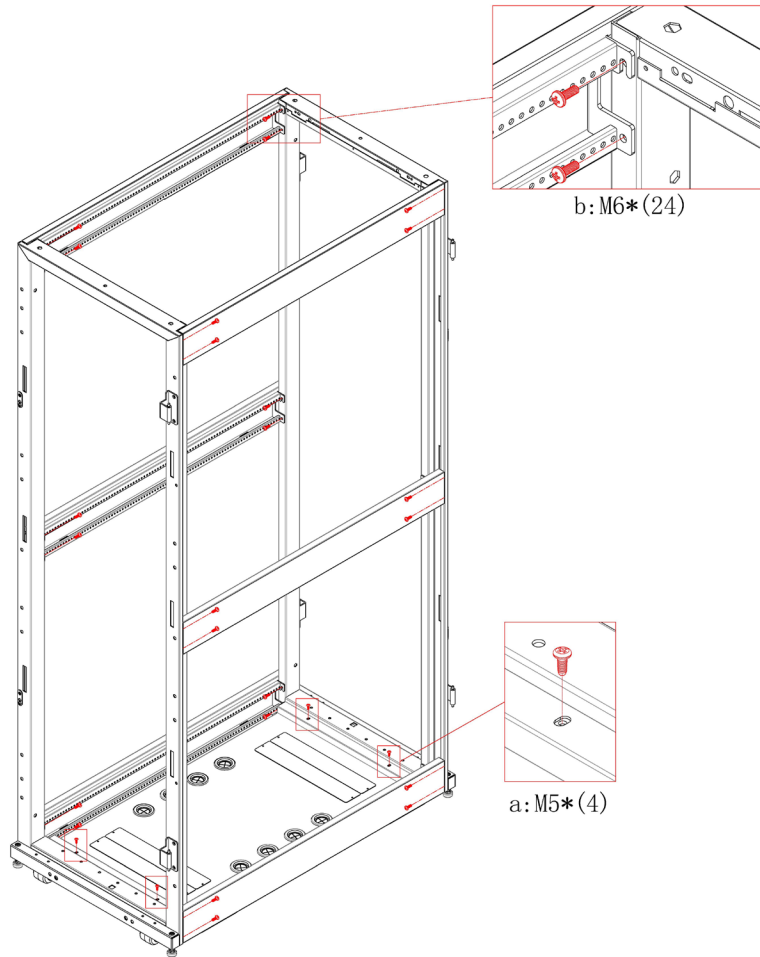



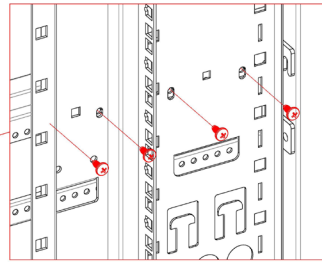

a: M5\*(36)

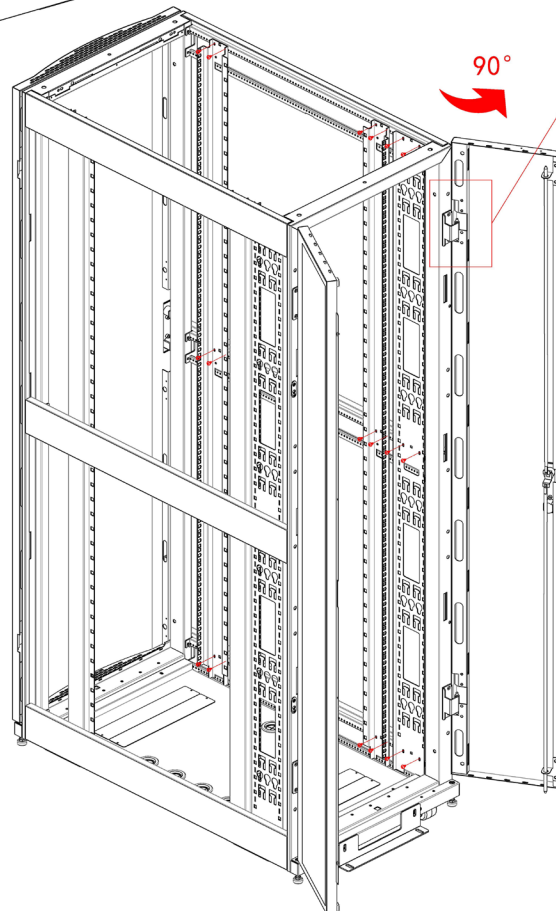

90° drop installation

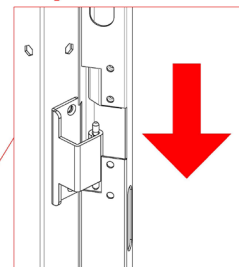

Pulling pin installation (pre-installed)

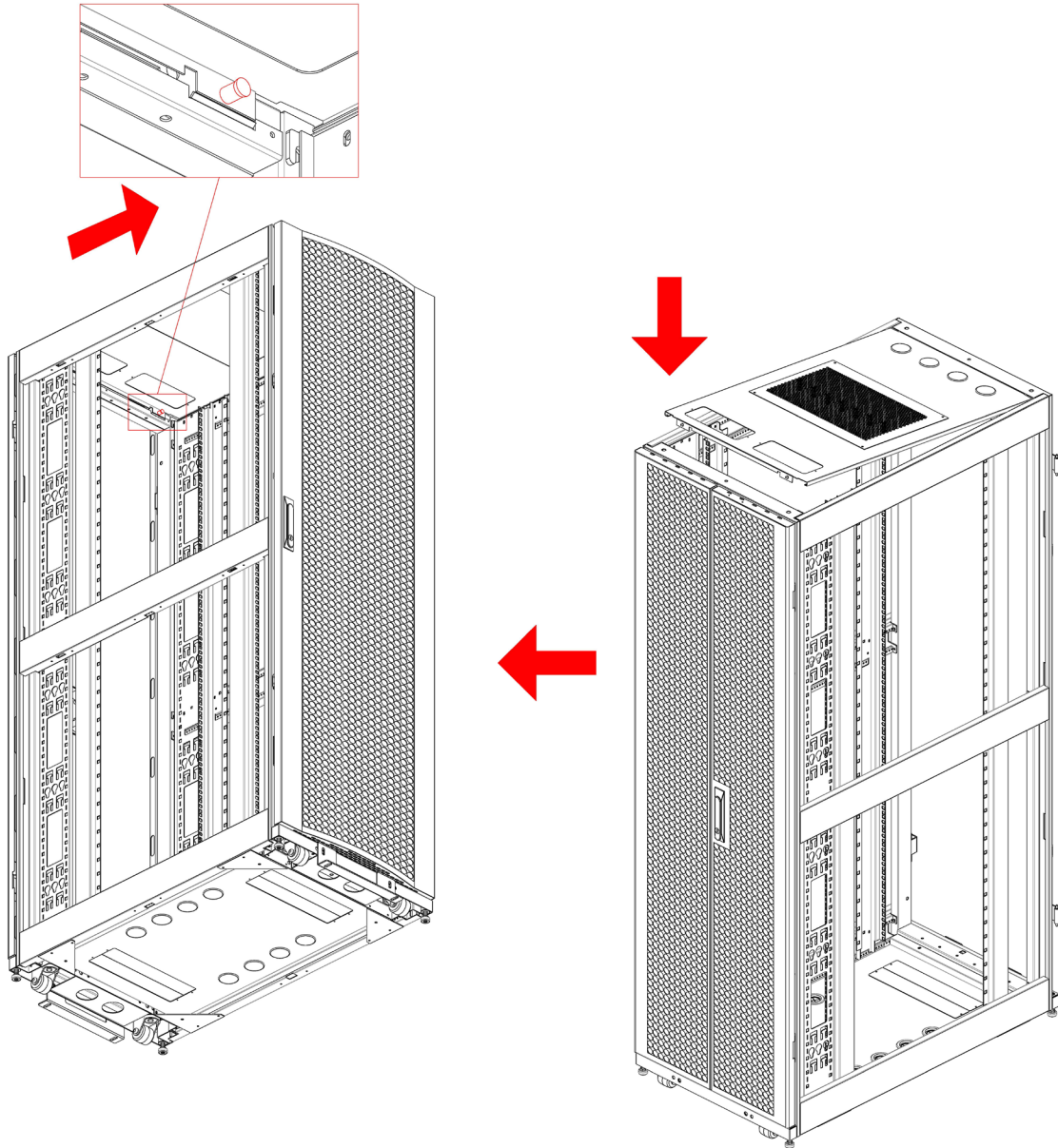

# Show Me™

CABLES

an INFINIT® brand

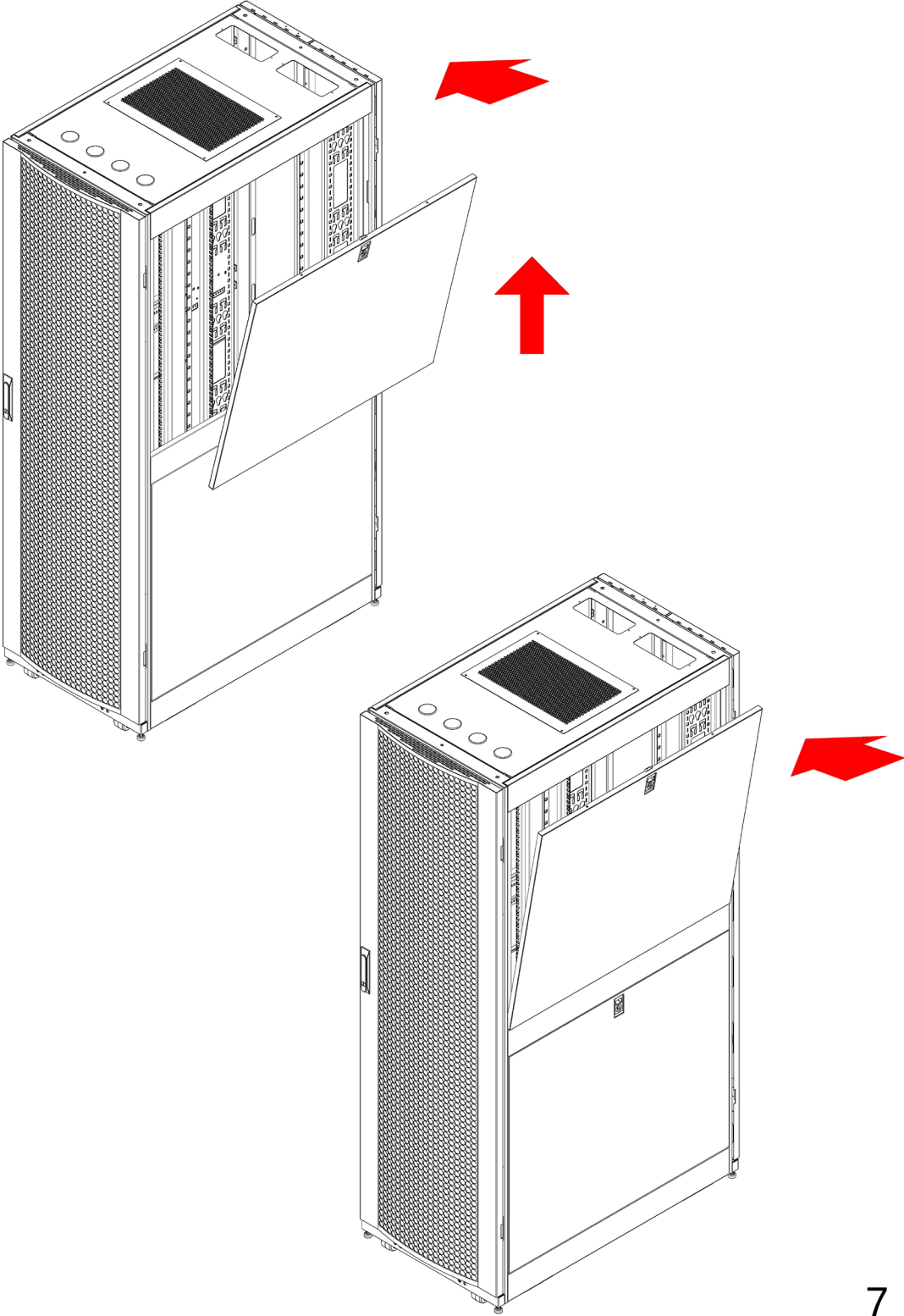

# Show Me™

C A B L E S

an INFINIT® brand

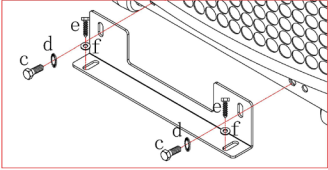
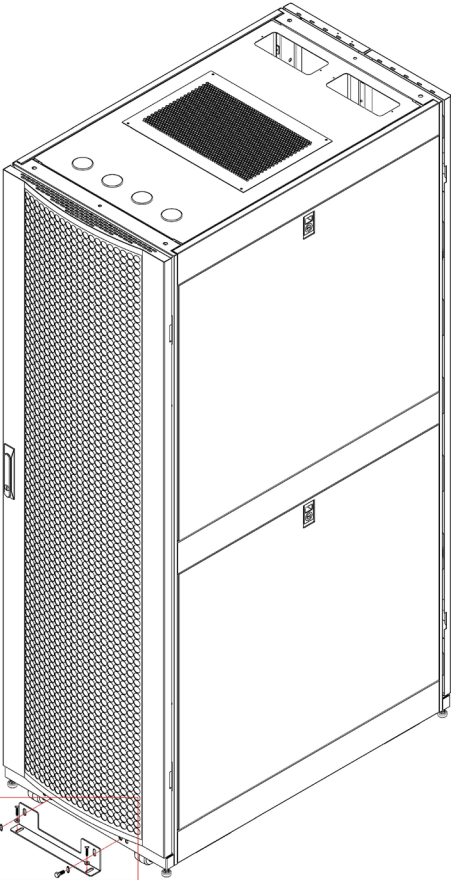

c: M8\*(4)      e: M8\*(4)  
d: M8\*(4)      f: M8\*(4)

