

8 7 6 5 4 3 2 1

THE INFORMATION CONTAINED IN THIS DRAWING IS THE SOLE PROPERTY OF SHOW ME CABLES, INC. ANY REPRODUCTION IN PART OR WHOLE WITHOUT THE WRITTEN PERMISSION OF SHOW ME CABLES, INC. IS PROHIBITED.

REVISIONS			
REV	DESCRIPTION	DATE	APPROVED
B	ECN 12128: UPDATE CABLE CALLOUT WORDING	10/14/2022	DGUST

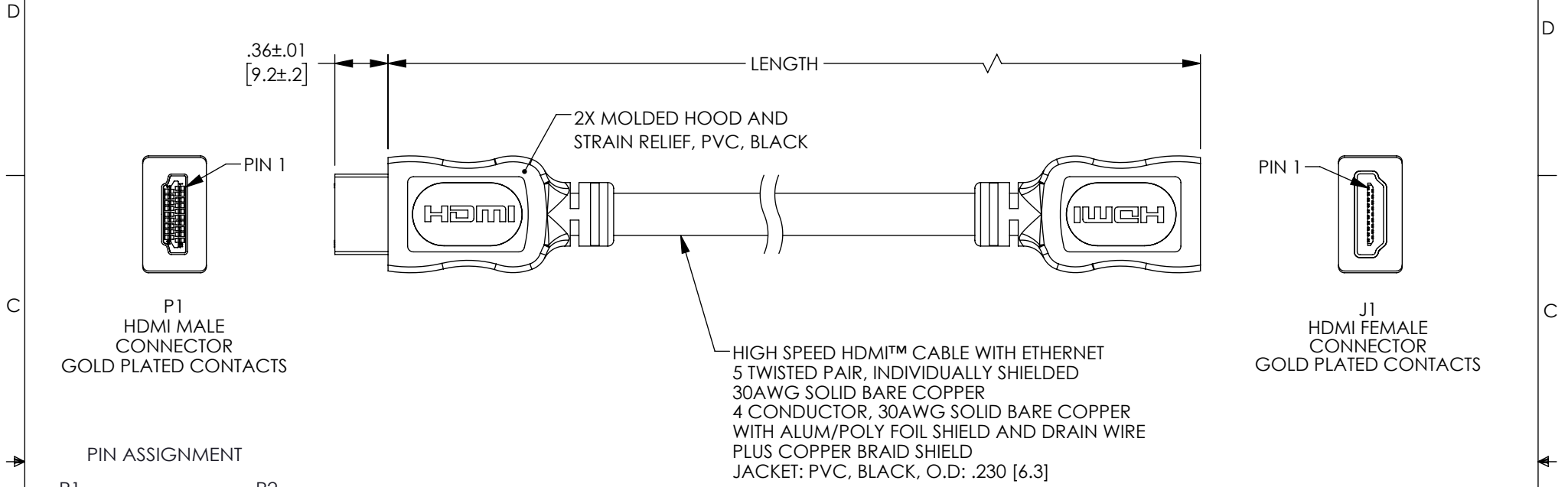

PIN ASSIGNMENT

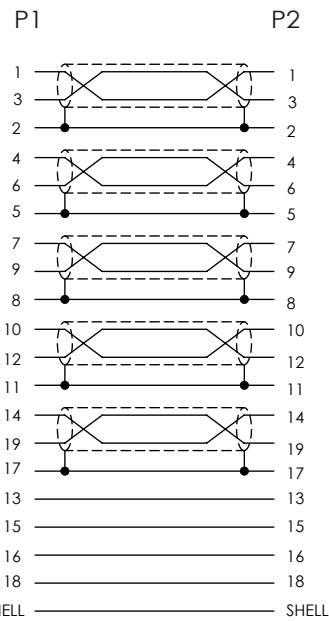

MODEL NO.	LENGTH(mm)	INCHES
41-155-001	305±30	12.0±1.18
41-155-002	610±30	24.0±1.18
41-155-003	915±30	36.0±1.18

NOTES:

- ELECTRICAL TEST:
 - CABLE ASSEMBLY SHALL BE TESTED FOR CONTINUITY.
 - CONTACT RESISTANCE: 5 OHM MAX
 - INSULATION RESISTANCE: 5M OHM MIN
 - HI-POT TEST: DC 300V/10ms
 - PASS 4K@60Hz TEST
- PACKAGING:

CABLE ASSEMBLY SHALL BE INDIVIDUALLY PACKAGED. INTO A CLEAR POLYBAG, LABEL PER LSP-010.

UNLESS OTHERWISE SPECIFIED, DIMENSIONS ARE IN INCHES [mm] OVERALL CABLE LENGTH TOLERANCE: ≤12 [305] = +1 [25] / -0 >12 [305] ≤60 [1524] = +2 [51] / -0 >60 [1524] ≤120 [3048] = +4 [102] / -0 >120 [3048] ≤300 [7620] = +6 [152] / -0 >300 [7620] = +5% / -0 ALL OTHER DIMENSIONAL TOLERANCES: .X = ± .2 [5] FRACTIONS ± 1/32 .XX = ± .02 [.5] ANGLES ± 1° .XXX = ± .005 [.13]	APPROVALS DRAWN BY MVEERAPPAN CHECKED BY DFRISIELLO APPROVED BY MBLACKWOOD	DATE 28-09-2020 28-09-2020 28-09-2020	Show Me CABLES an INFINIT® brand 115 Chesterfield Industrial Blvd., Chesterfield, MO 63005 Phone: 1.888.519.9505 Fax: 1.888.519.9515
	CONFIGURATION DETAILS OF UNDIMENSIONED FEATURES MAY VARY COLOR VARIATIONS MAY OCCUR	CATEGORY AUDIO/VIDEO	PRODUCT DESCRIPTION High Speed HDMI Extension Cable, M/F
THIRD-ANGLE PROJECTION 	SIZE A	CAGE CODE 3SVT8	ITEM NO. 41-155
SCALE: NONE	CAD FILE: 41-155.SLDDRW	SHEET 1 OF 1	REV. B