

THE INFORMATION CONTAINED IN THIS DRAWING IS THE SOLE PROPERTY OF SHOW ME CABLES, INC. ANY REPRODUCTION IN PART OR WHOLE WITHOUT THE WRITTEN PERMISSION OF SHOW ME CABLES, INC. IS PROHIBITED.

REVISIONS			
REV	DESCRIPTION	DATE	APPROVED
A	INITIAL RELEASE	11/03/2020	MBLACKWOOD

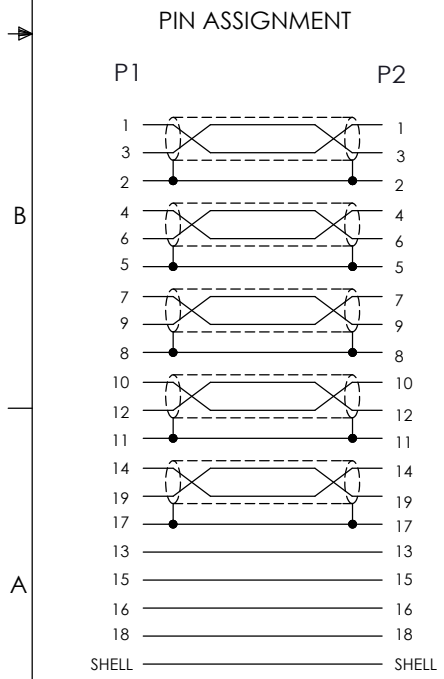
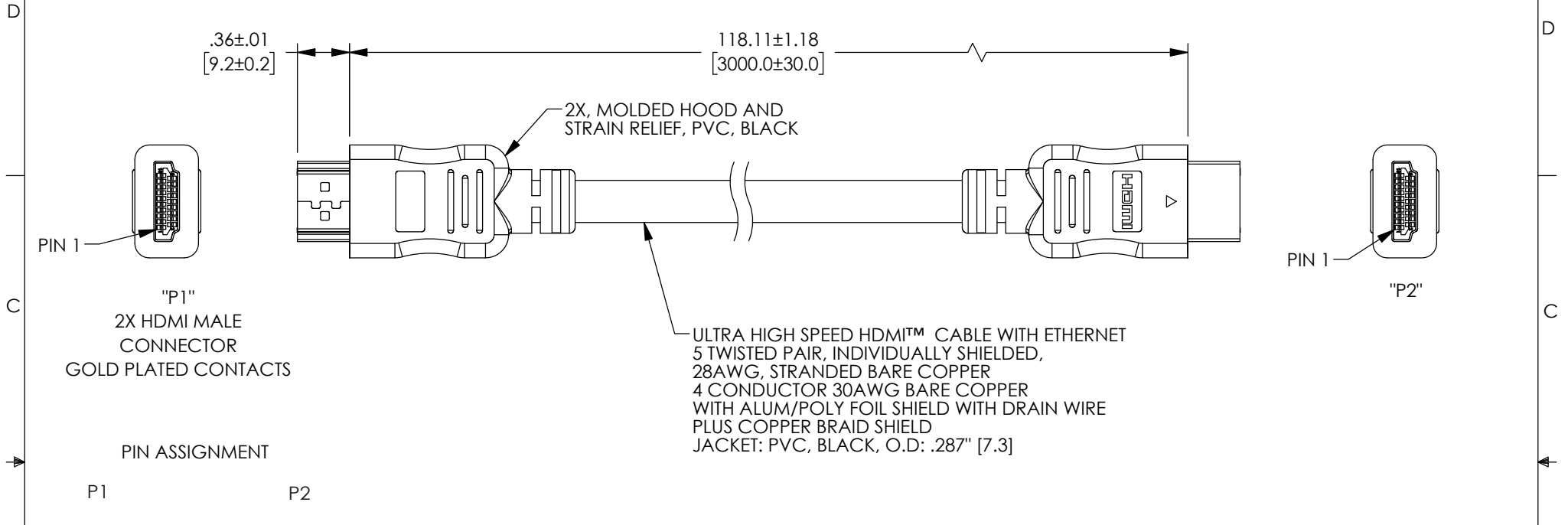

NOTES:

- ELECTRICAL TEST:**
 CABLE ASSEMBLY SHALL BE TESTED FOR CONTINUITY.
 CONTACT RESISTANCE: 5 OHM MAX
 INSULATION RESISTANCE: 5M OHM MIN
 HI-POT TEST: DC 300V/10ms
 PASS 8K@60Hz/48Gbps TEST
- PACKAGING:**
 CABLE ASSEMBLY SHALL BE INDIVIDUALLY PACKAGED INTO A CLEAR POLYBAG, LABEL PER LSP-010.

UNLESS OTHERWISE SPECIFIED, DIMENSIONS ARE IN INCHES [mm] OVERALL CABLE LENGTH TOLERANCE: ≤12 [305] = +1 [25] / -0 >12 [305] ≤60 [1524] = +2 [51] / -0 >60 [1524] ≤120 [3048] = +4 [102] / -0 >120 [3048] ≤300 [7620] = +6 [152] / -0 >300 [7620] = +5% / -0 ALL OTHER DIMENSIONAL TOLERANCES: .X = ± .2 [5] FRACTIONS ± 1/32 .XX = ± .02 [.5] ANGLES ± 1° .XXX = ± .005 [.13]	APPROVALS DRAWN BY: MVEERAPPAN CHECKED BY: DFRISIELLO APPROVED BY: MBLACKWOOD	DATE 09/28/2020 09/28/2020 09/28/2020	Show Me CABLES an INFINIT® brand 115 Chesterfield Industrial Blvd., Chesterfield, MO 63005 Phone: 1.888.519.9505 Fax: 1.888.519.9515
	CONFIGURATION DETAILS OF UNDIMENSIONED FEATURES MAY VARY COLOR VARIATIONS MAY OCCUR	CATEGORY AUDIO/VIDEO	PRODUCT DESCRIPTION ULTRA HIGH SPEED HDMI CABLE, M/M
THIRD-ANGLE PROJECTION 	SIZE A	CAGE CODE 3SVT8	ITEM NO. 41-153-03M
REV. A	SHEET 1 OF 1		